

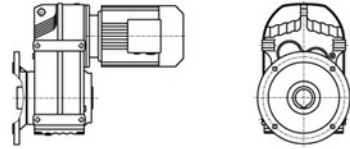

F系列减速机有以下设计方案：

F series gear units are available in the following designs:



FAF..Y..

法兰空心轴安装平行轴斜齿轮减速机

Flange-mounted parallel shaft helical gear units with hollow shaft

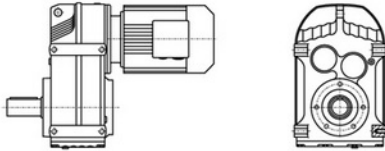

F..Y..

底脚轴伸式安装平行轴斜齿轮减速机

Foot-mounted parallel shaft helical gear units with solid shaft

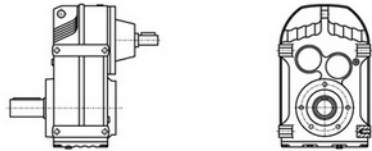

F (FF、FA、FAF、FAZ) S...

轴输入的平行轴斜齿轮减速机

Shaft input parallel shaft helical gear units

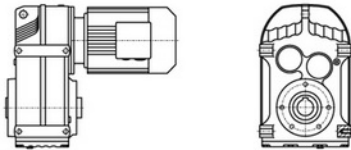

FA..Y..

空心轴安装平行轴斜齿轮减速机

Parallel shaft helical gear units with hollow shaft

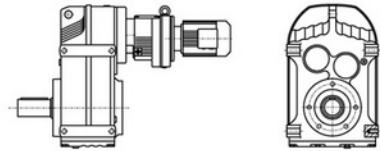

F (FF、FA、FAF、FAZ) ...R...Y...

组合式平行轴斜齿轮减速机

Combinatorial parallel shaft helical gear units

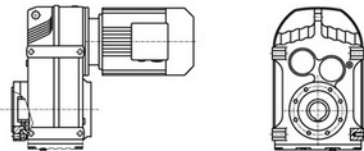

FAZ..Y..

小法兰空心轴安装平行轴斜齿轮减速机

Short-flange-mounted parallel shaft helical gear units with hollow shaft

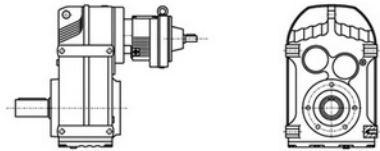

F (FF、FA、FAF、FAZ) S...R...

轴输入的组合适并轴斜齿轮减速机

Shaft input combinatorial parallel shaft helical gear units

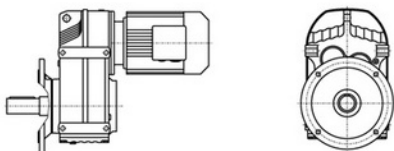

FF..Y..

法兰轴伸式安装平行轴斜齿轮减速机

Flange-mounted parallel shaft helical gear units with solid shaft

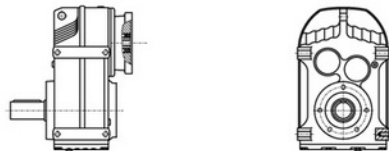

F (FF、FA、FAF、FAZ) ...Y...

电机用户自配或配特殊电机时需加联接法兰

When equipping the user's motor or the special one, the flange is required to be connected

型号与标记:

Type Designations:

<p style="text-align: center;">F F 37-Y 0.55-4P-23.88-M1- 270°</p>	<p style="text-align: center;">F F 37-Y 0.55-4P-23.88-M1- 270°</p>
<p>减速机型: 平行轴斜齿轮减速机</p>	<p>Gear units type: Parallel shaft helical gear units</p>
<p>结构形式:</p> <ul style="list-style-type: none"> 普通轴伸式 (省略) 轴装式 A 轴伸法兰式 F 轴装法兰式 AF 轴装小法兰式 AZ 普通轴伸式, 轴输入 S 普通轴装式, 轴输入 AS 轴伸法兰式, 轴输入 FS 轴装法兰式, 轴输入 AFS 	<p>Structure:</p> <ul style="list-style-type: none"> Foot-mounted solid shaft output (-) Hollow shaft output A Flange-mounted solid shaft output F Flange-mounted hollow shaft output AF Short-flange-mounted hollow shaft output AZ Foot-mounted solid shaft output, shaft input S Hollow shaft output, shaft input AS Flange-mounted solid shaft output, shaft input FS Flange-mounted hollow shaft output, shaft input AFS
<p>规格: (见选型参数表)</p>	<p>Size: (see selection table)</p>
<p>电机代号:</p> <ul style="list-style-type: none"> 普通 (更新) Y(Y2) 防 爆 B 直 流 Z 制 动 YEJ 多 速 D 变 频 YVP 电磁调速 YCT 冶金起重 R 变频制动 YVPJ 辊 道 G 	<p>Motor code:</p> <ul style="list-style-type: none"> Ordinary (renew) Y(Y2) Flame-proof B Direct current Z Brake YEJ Multi-speed D Variable frequency YVP Electromagnetism speed modulation YCT Hoisting in metallurgy R Variable frequency and brake YVPJ Roller tables G
<p>电机功率、极数: (见选型参数表)</p>	<p>Motor power, pole : (see selection table)</p>
<p>传动比: (见选型参数表)</p>	<p>Ratio: (see selection table)</p>
<p>安装形式: M1、M2、M3、M4、M5、M6 (见第129页)</p>	<p>Mounting position: M1、M2、M3、M4、M5、M6 (see page 129)</p>
<p>电机接线盒位置: 0°、90°、180°、270° (见第129页)</p>	<p>Position of the motor thermal box: 0°、90°、180°、270° (see page 129)</p>

安装形式:
Mounting position:

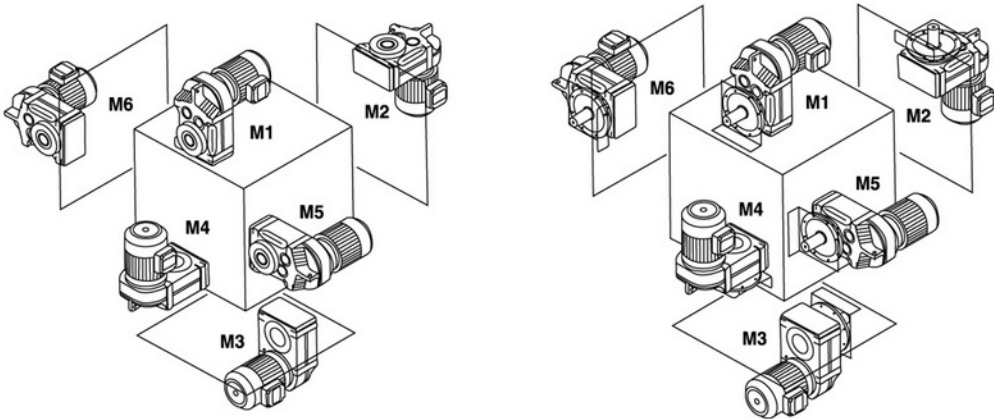

电机接线盒位置:
Position of the motor thermal box

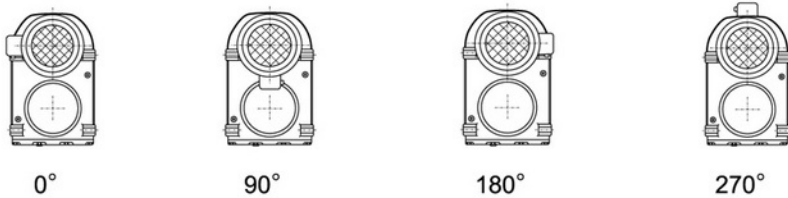

输入功率及许用转矩
Input power rating and permissible torque

规格 Size	37	47	57	67	77	87	97	107	127	157
结构形式 Structure	F FA FF FAF FAZ									
输入功率 Input power rating(kw)	0.18~3	0.18~3	0.18~5.5	0.18~5.5	0.37~11	0.75~22	1.1~30	2.2~45	7.5~90	11~200
传动比 Ratio	3.81~128.51	5.06~189.39	5.18~199.70	4.21~228.99	4.30~281.71	4.12~270.68	4.68~280.76	6.20~254.40	4.63~172.17	11.92~267.43
许用转矩(N.m) Permissible torque	200	400	600	820	1500	3000	4300	7840	12000	18000

减速机重量
Gear unit weight

规格 Size	37	47	57	67	77	87	97	107	127	157
重量 (kg) Weight	13	18	34	55	90	150	260	402	700	950

所注重量为平均值, 仅供参考

The weights are mean values, only for reference.

润滑油量表
Lubrication table

F...:

规格 Size	润滑油量 (升)			Fill quantity in liters		
	M1	M2	M3	M4	M5	M6
F37	1	1.2	0.7	1.2	1	1.1
F47	1.5	1.8	1.1	1.9	1.5	1.7
F57	2.6	3.7	2.1	3.5	2.8	2.9
F67	2.7	3.8	1.9	3.8	2.9	3.2
F77	5	7.3	4.3	8	6	6.3
F87	10	13.0	7.7	13.8	10.8	11
F97	18.5	22.5	12.6	25.2	18.5	20
F107	24.5	32	19.5	37.5	27	27
F127	40.5	55	34	61	46.5	47
F157	69	104	63	105	86	78

FF...:

规格 Size	润滑油量 (升)			Fill quantity in liters		
	M1	M2	M3	M4	M5	M6
FF37	1	1.2	0.7	1.3	1	1.1
FF47	1.6	1.9	1.1	1.9	1.5	1.7
FF57	2.8	3.8	2.1	3.7	2.9	3
FF67	2.7	3.8	1.9	3.8	2.9	3.2
FF77	5.1	7.3	4.3	8.1	6	6.3
FF87	10.3	13.2	7.8	14.1	11	11.2
FF97	19	22.5	12.6	25.5	18.9	20.5
FF107	25.5	32	19.5	38.5	27.5	28
FF127	41.5	56	34	63	46.5	49
FF157	72	105	64	106	87	79

FA...、FAF...、FAZ...:

规格 Size	润滑油量 (升)			Fill quantity in liters		
	M1	M2	M3	M4	M5	M6
F..37	1	1.2	0.7	1.2	1	1.1
F..47	1.5	1.8	1.1	1.9	1.5	1.7
F..57	2.7	3.8	2.1	3.6	2.9	3
F..67	2.7	3.8	1.9	3.8	2.9	3.2
F..77	5	7.3	4.3	8	6	6.3
F..87	10	13.0	7.7	13.8	10.8	11
F..97	18.5	22.5	12.6	25.0	18.5	20
F..107	24.5	32	19.5	37.5	27	27
F..127	39	55	34	61	45	46.5
F..157	68	103	62	104	85	77

输出转速	输出扭矩	传动比	使用系数	机型号	极数	输出转速	输出扭矩	传动比	使用系数	机型号	极数
Output speed	Output torque	Ratio	Service factor	Type	Pole	Output speed	Output torque	Ratio	Service factor	Type	Pole
r/min	Nm	i	f _s	Type	p	r/min	Nm	i	f _s	Type	p
0.18kW						0.18kW					
0.11	14324	13014	0.79			2.5	616	560	0.92		
0.12	12930	11748	0.87	FA 127R77	4	2.7	558	507	1.01		
0.14	11305	10271	1.00	FAF127R77	4	3.1	499	453	1.13		
0.16	9797	8901	1.15	F 127R77	4	3.3	469	426	1.20	FA 57R37	4
0.18	8478	7703	1.33	FF 127R77	4	3.6	426	387	1.32	FAF57R37	4
0.21	7449	6768	1.51			4.2	363	330	1.55	F 57R37	4
						4.7	328	298	1.72	FF 57R37	4
0.16	9408	8548	0.78			5.3	288	262	1.96		
0.18	8448	7675	0.87			6.2	249	226	2.3		
0.21	7281	6615	1.01			7.0	220	200	2.6		
0.24	6406	5820	1.15	FA 107R77	4						
0.27	5749	5223	1.28	FAF107R77	4	4.1	371	337	1.01		
0.30	5027	4567	1.47	F 107R77	4	4.6	331	301	1.13		
0.39	3875	3521	1.90	FF 107R77	4	4.7	322	293	1.17		
0.46	3343	3037	2.2			4.9	314	285	1.20	FA 47R17	4
0.50	3033	2756	2.4			6.0	253	230	1.49	FAF47R17	4
0.59	2607	2369	2.8			6.1	250	227	1.50	F 47R17	4
0.67	2276	2068	3.2			6.4	238	216	1.58	FF 47R17	4
						7.4	207	188	1.82		
0.32	4815	4375	0.84			7.9	194	176	1.94		
0.35	4343	3946	0.9								
0.41	3743	3401	1.1			8.2	187	170	1.00	FA 37R17	4
0.47	3246	2949	1.2	FA 97R57	4	8.3	185	168	1.02	FAF37R17	4
0.54	2851	2590	1.4	FAF97R57	4	10	146	133	1.28	F 37R17	4
0.61	2495	2267	1.6	F 97R57	4	11	142	129	1.32	FF 37R17	4
0.70	2189	1989	1.8	FF 97R57	4						
0.80	1914	1739	2.1			3.0	536	281.71	2.6	FA 77	6
0.90	1697	1542	2.4			3.2	500	262.93	2.8	FAF77	6
1.0	1475	1340	2.7			3.8	429	225.79	3.3	F 77	6
1.2	1301	1182	3.1							FF 77	6
0.48	3171	2881	0.9			3.7	435	228.99	1.77	FA 67	6
0.54	2834	2575	1.0			4.4	371	195.39	2.1	FAF67	6
0.63	2420	2199	1.2			5.0	325	170.85	2.4	F 67	6
0.72	2124	1930	1.3	FA 87R57	4					FF 67	6
0.81	1881	1709	1.5	FAF87R57	4						
0.93	1643	1493	1.7	F 87R57	4						
1.1	1431	1300	2.0	FF 87R57	4	6.1	266	228.99	2.9	FA 67	4
1.2	1264	1148	2.2			7.1	227	195.39	3.4	FAF67	4
1.4	1112	1010	2.5			8.1	199	170.85	3.9	F 67	4
1.6	976	887	2.9							FF 67	4
1.8	859	780	3.3								
0.8	1902	1728	0.7			4.3	380	199.70	1.49		
0.9	1698	1543	0.8			4.6	349	183.60	1.62	FA 57	6
1.0	1490	1354	0.9	FA 77R37	4	5.4	299	157.09	1.89	FAF57	6
1.2	1316	1196	1.1	FAF77R37	4	6.2	259	136.16	2.2	F 57	6
1.3	1156	1050	1.2	F 77R37	4	6.7	242	127.27	2.3	FF 57	6
1.5	998	907	1.4	FF 77R37	4	7.7	209	110.01	2.7		
1.7	892	810	1.6								
2.0	781	710	1.8			7.0	232	199.70	2.4	FA 57	4
2.3	660	600	2.1			7.6	213	183.60	2.6	FAF57	4
						8.8	183	157.09	3.1	F 57	4
						10	158	136.16	3.6	FF 57	4
						11	148	127.27	3.8		
1.6	944	858	0.82			4.5	360	189.39	1.0	FA 47	6
1.9	812	738	0.95			4.9	331	174.13	1.1	FAF47	6
2.2	689	626	1.12			5.7	283	148.98	1.3	F 47	6
2.4	630	572	1.22			6.6	245	129.14	1.5	FF 47	6
2.8	550	500	1.40			7.0	229	120.70	2.5		
2.8	547	497	1.41	FA 67R37	4						
3.1	500	454	1.54	FAF67R37	4						
3.3	470	427	1.64	F 67R37	4						
3.5	431	392	1.79	FF 67R37	4						
3.8	403	366	1.91			7.3	220	189.39	1.71	FA 47	4
4.2	367	333	2.1			8.0	202	174.13	1.86	FAF47	4
4.7	327	297	2.4			9.3	173	148.98	2.2	F 47	4
5.3	287	261	2.7			11	150	129.14	2.5	FF 47	4
5.8	262	238	2.9			12	140	120.70	2.7		
7.0	220	200	3.5								

F

输出转速	输出扭矩	传动比	使用系数	机型号	极数	输出转速	输出扭矩	传动比	使用系数	机型号	极数
Output speed	Output torque	Ratio	Service factor	Type	Pole	Output speed	Output torque	Ratio	Service factor	Type	Pole
r/min	Nm	i	f _s	Type	p	r/min	Nm	i	f _s	Type	p
0.18kW						0.25kW					
7.2	224	117.88	0.84	FA 37	6	0.72	2950	1930	1.0		
8.5	191	100.36	0.99	FAF37	6	0.81	2613	1709	1.1		
9.8	164	86.53	1.14	F 37	6	0.93	2282	1493	1.2	FA 87R57	4
11	153	80.65	1.23	FF 37	6	1.1	1987	1300	1.4	FAF87R57	4
12	134	70.50	1.40			1.2	1755	1148	1.6	F 87R57	4
11	149	128.51	1.26			1.4	1544	1010	1.8	FF 87R57	4
12	137	117.88	1.37			1.6	1356	887	2.1		
14	117	100.36	1.61			1.8	1192	780	2.4		
16	101	86.53	1.87			2.1	1030	674	2.7		
17	94	80.65	2.0			1.3	1605	1050	0.88		
20	82	70.50	2.3			1.5	1387	907	1.02		
21	77	66.09	2.4			1.7	1238	810	1.14	FA 77R37	4
24	68	58.32	2.8			2.0	1085	710	1.30	FAF77R37	4
25	63	54.54	3.0			2.3	917	600	1.54	F 77R37	4
27	60	51.70	3.1			2.6	803	525	1.76	FF 77R37	4
30	55	47.02	3.4			3.0	717	469	1.97		
32	51	43.83	3.7			3.4	630	412	2.2		
36	45	38.31	4.2			2.2	980	641	0.79		
39	42	35.91	4.5	FA 37	4	2.4	874	572	0.88		
44	37	31.69	5.1	FAF37	4	2.7	778	509	0.99		
49	33	28.09	5.8	F 37	4	2.8	764	500	1.01	FA 67R37	4
58	28	23.88	6.8	FF 37	4	3.1	694	454	1.11	FAF67R37	4
59	27	23.63	6.8			3.2	668	437	1.15	F 67R37	4
68	24	20.57	7.9			3.5	599	392	1.29	FF 67R37	4
72	22	19.27	8.4			4.2	509	333	1.51		
82	20	17.03	9.5			4.7	454	297	1.70		
88	18	15.81	10.2			5.3	399	261	1.93		
97	17	14.33	11			5.8	364	238	2.1		
108	15	12.87	13			3.6	592	387	0.95		
125	13	11.08	14			4.2	504	330	0.97		
133	12	10.42	14			5.6	381	249	1.11		
155	10	8.97	16			3.6	584	382	1.12	FA 57R37	4
185	8.7	7.51	16			4.2	505	330	1.21	FAF57R37	4
204	7.9	6.81	17			4.7	456	298	1.24	F 57R37	4
227	7.1	6.11	18			5.3	401	262	1.48	FF 57R37	4
264	6.1	5.27	19			6.2	345	226	1.63		
281	5.8	4.95	20			7.0	306	200	1.84		
326	5.0	4.26	21			8.4	254	166	2.2		
0.25kW						0.25kW					
0.16	13607	8901	0.83			6.0	352	230	1.07		
0.18	11775	7703	0.96	FA 127R77	4	6.1	347	227	1.08		
0.21	10346	6768	1.09	FAF127R77	4	6.4	330	216	1.14		
0.23	9131	5973	1.24	F 127R77	4	7.2	294	192	1.28	FA 47R17	4
0.27	7760	5076	1.45	FF 127R77	4	7.4	287	188	1.31	FAF47R17	4
0.31	6827	4466	1.7			7.9	269	176	1.40	F 47R17	4
0.24	8897	5820	0.83			8.0	264	173	1.42	FF 47R17	4
0.27	7984	5223	0.92			9.4	226	148	1.66		
0.30	6982	4567	1.06			11	199	130	1.89		
0.40	5262	3442	1.40	FA 107R77	4	10	203	133	0.92	FA 37R17	4
0.46	4643	3037	1.59	FAF107R77	4	11	197	129	0.95	FAF37R17	4
0.50	4213	2756	1.75	F 107R77	4	12	180	118	1.04	F 37R17	4
0.59	3621	2369	2.0	FF 107R77	4	14	150	98	1.25	FF 37R17	4
0.67	3161	2068	2.3			16	133	87	1.41		
0.87	2441	1597	3.0			3.0	744	281.71	1.9	FA 77	6
0.99	2142	1401	3.4			3.2	694	262.93	2.0	FAF77	6
0.47	4508	2949	0.90			3.8	596	225.79	2.4	F 77	6
0.54	3959	2590	1.02			4.3	524	198.31	2.7	FF 77	6
0.61	3466	2267	1.17	FA 97R57	4	4.5	497	188.40	2.8		
0.63	3362	2199	1.20	FAF97R57	4						
0.80	2658	1739	1.52	F 97R57	4						
0.90	2357	1542	1.71	FF 97R57	4						
1.0	2032	1329	2.0								
1.2	1807	1182	2.2								
1.3	1578	1032	2.6								

输出转速	输出扭矩	传动比	使用系数	机型号	极数	输出转速	输出扭矩	传动比	使用系数	机型号	极数
Output speed	Output torque	Ratio	Service factor	Type	Pole	Output speed	Output torque	Ratio	Service factor	Type	Pole
r/min	Nm	i	f _s	Type	p	r/min	Nm	i	f _s	Type	p
0.25kW						0.25kW					
3.7	605	228.99	1.3	FA 67	6	204	11	6.81	12	FA 37	4
4.4	516	195.39	1.5	FAF67	6	227	10	6.11	13	FAF37	4
5.0	451	170.85	1.7	F 67	6	264	8.5	5.27	14	F 37	4
5.2	429	162.31	1.8	FF 67	6	281	8.0	4.95	14	F 37	4
6.0	376	142.40	2.1			326	6.9	4.26	15	FF 37	4
6.1	370	228.99	2.1	FA 67	4	0.37kW					
7.1	315	195.39	2.4	FAF67	4	0.21	15312	6768	0.74		
8.1	276	170.85	2.8	F 67	4	0.23	13514	5973	0.83	FA 127R77	4
8.6	262	162.31	2.9	FF 67	4	0.27	11484	5076	0.98	FAF127R77	4
9.8	230	142.40	3.4			0.31	10104	4466	1.12	F 127R77	4
4.3	527	199.70	1.07			0.36	8751	3868	1.29	FF 127R77	4
4.6	485	183.60	1.16	FA 57	6	0.41	7699	3403	1.47		
5.4	415	157.09	1.4	FAF57	6	0.47	6758	2987	1.67		
6.2	360	136.16	1.6	F 57	6	0.46	6871	3037	1.07	FA 107R77	4
6.7	336	127.27	1.7	FF 57	6	0.50	6235	2756	1.16	FAF107R77	4
7.7	290	110.01	1.9			0.59	5360	2369	1.35	F 107R77	4
7.0	322	199.70	1.7			0.67	4679	2068	1.54	FF 107R77	4
7.6	296	183.60	1.9	FA 57	4	0.87	3613	1597	2.0		
8.8	254	157.09	2.2	FAF57	4	0.61	5129	2267	0.79		
10	220	136.16	2.6	F 57	4	0.70	4505	1991	0.90		
11	205	127.27	2.7	FF 57	4	0.80	3934	1739	1.03	FA 97R57	4
13	178	110.01	3.2			0.90	3489	1542	1.16	FAF97R57	4
5.7	393	148.98	1.0	FA 47	6	1.0	3032	1340	1.3	F 97R57	4
6.6	341	129.14	1.1	FAF47	6	1.2	2674	1182	1.5	FF 97R57	4
7.0	319	120.70	1.2	F 47	6	1.3	2335	1032	1.7		
8.1	275	104.33	1.4	FF 47	6	1.5	2052	907	2.0		
7.3	306	189.39	1.2			1.1	2941	1300	1.0		
8.0	281	174.13	1.3	FA 47	4	1.2	2597	1148	1.1		
9.3	241	148.98	1.6	FAF47	4	1.4	2285	1010	1.2	FA 87R57	4
11	209	129.14	1.8	F 47	4	1.6	2007	887	1.4	FAF87R57	4
12	195	120.70	1.9	FF 47	4	1.8	1765	780	1.6	F 87R57	4
13	168	104.33	2.2			2.1	1525	674	1.8	FF 87R57	4
16	143	88.65	2.6			2.3	1378	609	2.0		
						2.7	1165	515	2.4		
						3.1	1023	452	2.8		
11	207	128.51	0.9			1.7	1833	810	0.77		
12	190	117.88	1.0			2.0	1606	710	0.88		
14	162	100.36	1.2			2.3	1357	600	1.04	FA 77R37	4
16	140	86.53	1.3			2.6	1188	525	1.19	FAF77R37	4
17	130	80.65	1.4			3.0	1061	469	1.33	F 77R37	4
20	114	70.50	1.7			3.4	932	412	1.51	FF 77R37	4
21	107	66.09	1.8			3.9	808	357	1.75		
24	94	58.32	2.0			4.4	710	314	1.98		
25	88	54.54	2.1			3.3	966	427	0.80		
27	83	51.70	2.3	FA 37	4	3.8	828	366	0.93	FA 67R37	4
30	76	47.02	2.5	FAF37	4	4.3	731	323	1.05	FAF67R37	4
32	71	43.83	2.7	F 37	4	4.8	656	290	1.17	F 67R37	4
36	62	38.31	3.0	FF 37	4	5.4	581	257	1.33	FF 67R37	4
39	58	35.91	3.2			6.3	498	220	1.55		
44	51	31.69	3.7			5.3	593	262	0.95		
49	45	28.09	4.1			5.6	563	249	1.00		
58	39	23.88	4.9			6.2	511	226	1.10	FA 57R37	4
59	38	23.63	4.9			7.0	452	200	1.25	FAF57R37	4
68	33	20.57	5.7			7.1	446	197	1.27	F 57R37	4
72	31	19.27	6.0			7.7	410	181	1.38	FF 57R37	4
82	27	17.03	6.8			8.4	376	166	1.50		
88	26	15.81	7.4			9.1	344	152	1.64		
97	23	14.33	8.1			10	303	134	1.86		
108	21	12.87	9.0								
125	18	11.08	10								
133	17	10.42	10								
155	14	8.97	11								
185	12	7.51	11								

输出转速	输出扭矩	传动比	使用系数	机型号	极数	输出转速	输出扭矩	传动比	使用系数	机型号	极数
Output speed	Output torque	Ratio	Service factor	Type	Pole	Output speed	Output torque	Ratio	Service factor	Type	Pole
r/min	Nm	i	f _s	Type	p	r/min	Nm	i	f _s	Type	p
0.37kW						0.37kW					
8.0	391	173	0.96	FA 47R17	4	32	105	43.83	1.80		
9.5	330	146	1.14	FAF47R17	4	36	92	38.31	2.1		
11	292	129	1.29	F 47R17	4	39	86	35.91	2.2		
				FF 47R17	4	44	76	31.69	2.5		
2.4	1400	271.92	2.0	FA 87	8	49	67	28.09	2.8		
2.5	1313	254.93	2.1	FAF87	8	58	57	23.88	3.3		
2.8	1177	228.57	2.4	F 87	8	59	56	23.63	3.3		
3.3	1014	196.85	2.8	FF 87	8	68	49	20.57	3.8		
						72	46	19.27	4.1		
3.1	1063	271.92	2.7	FA 87	6	82	41	17.03	4.6	FA 37	4
3.3	996	254.93	2.8	FAF87	6	88	38	15.81	5.0	FAF37	4
3.7	893	228.57	3.2	F 87	6	97	34	14.33	5.5	F 37	4
				FF 87	6	108	31	12.87	6.1	FF 37	4
						125	26	11.08	6.7		
3.8	882	225.79	1.6	FA 77	6	133	25	10.42	7.0		
4.3	775	198.31	1.8	FAF77	6	155	21	8.97	7.6		
4.5	736	188.40	1.9	F 77	6	185	18	7.51	7.7		
5.1	651	166.47	2.2	FF 77	6	204	16	6.81	8.1		
6.0	556	142.27	2.5		6	227	15	6.11	8.7		
						264	13	5.27	9.3		
4.9	673	281.71	2.1	FA 77	4	281	12	4.95	9.5		
5.3	628	262.93	2.2	FAF77	4	326	10	4.26	10		
6.2	540	225.79	2.6	F 77	4						
7.0	474	198.31	3.0	FF 77	4						
4.4	764	195.39	1.01	FA 67	6	0.22	21141	6286	0.80		
5.0	668	170.85	1.15	FAF67	6	0.26	18174	5404	0.93		
5.2	634	162.31	1.22	F 67	6	0.50	9336	2776	1.81	FA 157R97	4
6.0	556	142.40	1.4	FF 67	6	0.57	8162	2427	2.1	FAF157R97	4
7.0	472	120.79	1.6		6	0.83	5630	1674	3.0	F 157R97	4
						1.1	4399	1308	3.8	FF 157R97	4
						1.2	3931	1169	4.3		
6.1	547	228.99	1.41								
7.1	467	195.39	1.65	FA 67	4						
8.1	408	170.85	1.89	FAF67	4						
8.6	388	162.31	1.99	F 67	4						
9.8	340	142.40	2.3	FF 67	4						
12	289	120.79	2.7		4						
5.4	614	157.09	0.92	FA 57	6	0.36	13009	3868	0.87	FA 127R77	4
6.2	532	136.16	1.06	FAF57	6	0.41	11445	3403	0.99	FAF127R77	4
6.7	497	127.27	1.13	F 57	6	0.47	10046	2987	1.12	F 127R77	4
7.7	430	110.01	1.31	FF 57	6						
5.4	614	157.09	0.92	FA 57	6	0.59	7967	2369	0.92		
6.2	532	136.16	1.06	FAF57	6	0.67	6955	2068	1.06		
6.7	497	127.27	1.13	F 57	6	0.76	6141	1826	1.20		
7.7	430	110.01	1.31	FF 57	6	0.87	5371	1597	1.37	FA 107R77	4
						0.99	4712	1401	1.56	FAF107R77	4
7.0	477	199.70	1.18			1.19	3921	1166	1.88	F 107R77	4
7.6	439	183.60	1.29			1.28	3656	1087	2.0	FF 107R77	4
8.8	375	157.09	1.50	FA 57	4	1.46	3195	950	2.3		
10	325	136.16	1.73	FAF57	4	1.67	2805	834	2.6		
11	304	127.27	1.85	F 57	4	2.17	2152	640	3.4		
13	263	110.01	2.1	FF 57	4						
15	223	93.47	2.5								
17	199	83.46	2.8								
9	356	148.98	1.06			1.04	4507	1340	0.90		
11	309	129.14	1.22			1.18	3975	1182	1.02		
13	249	104.33	1.51	FA 47	4	1.35	3471	1032	1.16		
16	212	88.65	1.77	FAF47	4	1.5	3050	907	1.33	FA 97R57	4
18	189	79.15	2.0	F 47	4	1.7	2677	796	1.5	FAF97R57	4
21	162	67.61	2.3	FF 47	4	2.0	2354	700	1.7	F 97R57	4
21	155	64.89	2.4		4	2.3	2055	611	2.0	FF 97R57	4
						2.6	1796	534	2.3		
						2.9	1587	472	2.5		
						3.4	1379	410	2.9		
						3.8	1234	367	3.3		
16	207	86.53	0.91			1.6	2983	887	0.95		
17	193	80.65	0.98			1.8	2623	780	1.08	FA 87R57	4
20	168	70.50	1.12	FA 37	4	2.1	2267	674	1.24	FAF87R57	4
21	158	66.09	1.19	FAF37	4	2.3	2048	609	1.38	F 87R57	4
24	139	58.32	1.35	F 37	4	2.7	1732	515	1.63	FF 87R57	4
25	130	54.54	1.44	FF 37	4	3.1	1520	452	1.86		
27	124	51.70	1.52			4.0	1160	345	2.4		
30	112	47.02	1.67								

输出转速	输出扭矩	传动比	使用系数	机型号	极数	输出转速	输出扭矩	传动比	使用系数	机型号	极数
Output speed	Output torque	Ratio	Service factor	Type	Pole	Output speed	Output torque	Ratio	Service factor	Type	Pole
r/min	Nm	i	f _s	Type	p	r/min	Nm	i	f _s	Type	p
0.55kW						0.55kW					
2.6	1766	525	0.80	FA 77R37	4	21	230	64.89	1.63	FA 47	4
3.0	1577	469	0.89	FAF77R37	4	25	199	56.09	1.89	FAF47	4
3.4	1386	412	1.02	F 77R37	4	29	169	47.66	2.2	F 47	4
3.9	1201	357	1.17	FF 77R37	4	33	151	42.55	2.5	FF 47	4
4.4	1056	314	1.34								
5.4	864	257	0.89	FA 67R37	4	24	207	58.32	0.91		
6.3	740	220	1.04	FAF67R37	4	25	194	54.54	0.97		
7.1	659	196	1.17	F 67R37	4	27	184	51.70	1.02		
8.3	562	167	1.37	FF 67R37	4	30	167	47.02	1.13		
						32	156	43.83	1.21		
						36	136	38.31	1.38		
						39	128	35.91	1.47		
2.4	2039	276.64	1.98	FA 97	8	44	113	31.69	1.67		
2.6	1878	254.79	2.2	FAF97	8	49	100	28.09	1.88		
3.0	1668	226.34	2.4	F 97	8	58	85	23.88	2.2		
						59	84	23.63	2.2		
2.5	2004	271.92	1.41	FA 87	8	68	73	20.57	2.6	FA 37	4
2.6	1875	254.93	1.50	FAF87	8	72	68	19.27	2.7	FAF37	4
2.9	1684	228.57	1.67	F 87	8	82	60	17.03	3.1	F 37	4
3.4	1450	196.85	1.94	FF 87	8	97	51	14.33	3.7	FF 37	4
						108	46	12.87	4.1		
3.3	1517	271.92	1.86	FA 87	6	125	39	11.08	4.5		
3.5	1422	254.93	1.98	FAF87	6	133	37	10.42	4.7		
3.9	1275	228.57	2.2	F 87	6	155	32	8.97	5.1		
4.5	1098	196.85	2.6	FF 87	6	174	28	8.01	5.2		
4.9	998	178.95	2.8			185	27	7.51	5.4		
						204	24	6.81	5.6		
3.9	1260	225.79	1.12	FA 77	6	227	22	6.11	5.8		
4.5	1106	198.31	1.27	FAF77	6	264	19	5.27	6.3		
4.7	1051	188.40	1.34	F 77	6	281	18	4.95	6.4		
5.3	929	166.47	1.52	FF 77	6	326	15	4.26	6.8		
6.2	794	142.27	1.78			365	14	3.81	7.3		
6.8	728	130.42	1.94								
6.2	802	225.79	1.76			0.75kW					
7.0	704	198.31	2.0			0.50	12731	2776	1.33	FA 157R97	4
7.4	669	188.40	2.1	FA 77	4	0.57	11130	2427	1.52	FAF157R97	4
8.3	591	166.47	2.4	FAF77	4	0.83	7677	1674	2.2	F 157R97	4
9.8	505	142.27	2.8	F 77	4	1.1	5999	1308	2.8	FF 157R97	4
11	463	130.42	3.0	FF 77	4	1.2	5361	1169	3.2		
12	407	114.45	3.5								
13	385	108.46	3.7			0.47	13699	2987	0.82		
15	337	94.93	4.2			0.52	12350	2693	0.91	FA 127R77	4
						0.59	10896	2376	1.04	FAF127R77	4
7.1	694	195.39	1.11			0.68	9420	2054	1.20	F 127R77	4
8.1	607	170.85	1.27			0.77	8246	1798	1.37	FF 127R77	4
8.6	577	162.31	1.34			0.86	7425	1619	1.52		
9.8	506	142.40	1.52	FA 67	4						
12	429	120.79	1.80	FAF67	4	0.76	8374	1826	0.88		
13	387	109.04	2.0	F 67	4	0.88	7241	1597	1.02		
14	341	95.94	2.3	FF 67	4	0.99	6425	1401	1.15	FA 107R77	4
15	322	90.59	2.4			1.1	5700	1243	1.29	FAF107R77	4
18	277	77.97	2.8			1.3	4985	1087	1.48	F 107R77	4
						1.5	4357	950	1.69	FF 107R77	4
8.8	558	157.09	1.01			1.7	3825	834	1.93		
10	484	136.16	1.17			2.2	2875	627	2.6		
11	452	127.27	1.25	FA 57	4	3.3	1958	427	3.8		
13	391	110.01	1.44	FAF57	4						
15	332	93.47	1.70	F 57	4	1.3	4733	1032	0.85		
17	296	83.46	1.90	FF 57	4	1.5	4160	907	0.97		
19	260	73.16	2.2			1.7	3651	796	1.1	FA 97R57	4
20	243	68.38	2.3			2.0	3210	700	1.3	FAF97R57	4
24	210	59.10	2.7			2.3	2802	611	1.4	F 97R57	4
						2.6	2449	534	1.7	FF 97R57	4
13	371	104.33	1.01	FA 47	4	2.9	2165	472	1.9		
16	315	88.65	1.19	FAF47	4	3.4	1880	410	2.1		
18	281	79.15	1.34	F 47	4	3.8	1683	367	2.4		
21	240	67.61	1.57	FF 47	4						

F

输出转速	输出扭矩	传动比	使用系数	机型号	极数	输出转速	输出扭矩	传动比	使用系数	机型号	极数
Output speed	Output torque	Ratio	Service factor	Type	Pole	Output speed	Output torque	Ratio	Service factor	Type	Pole
r/min	Nm	i	f _s	Type	p	r/min	Nm	i	f _s	Type	p
0.75kW						0.75kW					
2.1	3091	674	0.91	FA 87R57	4	19	354	73.16	1.59	FA 57	4
2.3	2793	609	1.01	FAF87R57	4	20	331	68.38	1.70	FAF57	4
2.7	2362	515	1.19	F 87R57	4	24	286	59.10	1.97	F 57	4
3.1	2073	452	1.36	FF 87R57	4	28	243	50.22	2.3	FF 57	4
4.0	1582	345	1.78			31	217	44.84	2.6		
3.9	1637	357	0.86	FA 77R37	4	17	386	79.72	0.97		
4.4	1440	314	0.98	FAF77R37	4	20	330	68.09	1.14		
5.1	1247	272	1.13	F 77R37	4	21	317	65.36	1.19	FA 47	4
				FF 77R37	4	25	272	56.09	1.38	FAF47	4
						29	231	47.66	1.63	F 47	4
				FA 107	8	33	206	42.55	1.82	FF 47	4
2.7	2519	255.25	2.9	FAF107	8	38	176	36.34	2.1		
				F 107	8	41	165	34.04	2.3		
				FF 107	8	48	139	28.67	2.7		
2.5	2739	276.64	1.5	FA 97	8	30	228	47.02	0.83		
2.7	2523	254.79	1.6	FAF97	8	32	212	43.83	0.89		
3.0	2241	226.34	1.8	F 97	8	36	186	38.31	1.01		
				FF 97	8	39	174	35.91	1.08		
						44	153	31.69	1.22		
3.3	2047	276.64	2.0	FA 97	6	49	136	28.09	1.38		
3.6	1885	254.79	2.1	FAF97	6	58	116	23.88	1.63		
4.0	1675	226.34	2.4	F 97	6	59	114	23.63	1.6		
				FF 97	6	68	100	20.57	1.9		
						72	93	19.27	2.0	FA 37	4
3.3	2012	271.92	1.40			82	82	17.03	2.3	FAF37	4
3.6	1886	254.93	1.50	FA 87	6	97	69	14.33	2.7	F 37	4
4.0	1691	228.57	1.67	FAF87	6	108	62	12.87	3.0	FF 37	4
4.6	1456	196.85	1.94	F 87	6	125	54	11.08	3.3		
5.1	1324	178.95	2.1	FF 87	6	133	50	10.42	3.4		
5.7	1181	159.61	2.4			155	43	8.97	3.8		
						204	33	6.81	4.0		
						227	30	6.11	4.3		
5.1	1317	271.92	2.1	FA 87	4	264	26	5.27	4.6		
5.4	1235	254.93	2.3	FAF87	4	281	24	4.95	4.7		
6.1	1107	228.57	2.5	F 87	4	326	21	4.26	5.0		
				FF 87	4	365	18	3.81	5.3		
4.6	1467	198.31	0.96	FA 77	6	1.1kW					
4.8	1394	188.40	1.01	FAF77	6						
5.5	1232	166.47	1.14	F 77	6						
6.4	1053	142.27	1.34	FF 77	6						
7.0	965	130.42	1.46								
6.2	1094	225.79	1.29			0.50	18539	2776	0.91		
7.0	961	198.31	1.47			0.58	16208	2427	1.04		
7.4	913	188.40	1.55	FA 77	4	0.64	14592	2185	1.16		
8.3	806	166.47	1.75	FAF77	4	0.72	12982	1944	1.30	FA 157R97	4
9.8	689	142.27	2.0	F 77	4	0.84	11179	1674	1.51	FAF157R97	4
11	632	130.42	2.2	FF 77	4	1.1	8735	1308	1.94	F 157R97	4
12	554	114.45	2.5			1.2	7807	1169	2.2	FF 157R97	4
13	525	108.46	2.7			1.5	6364	953	2.7		
						1.7	5643	845	3.0		
						3.1	2978	446	5.7		
						4.7	2010	301	8.4		
8.1	828	170.85	0.93			0.68	13717	2054	0.82		
8.6	786	162.31	0.98			0.78	12007	1798	0.94	FA 127R77	4
9.8	690	142.40	1.12			0.86	10812	1619	1.04	FAF127R77	4
12	585	120.79	1.32	FA 67	4	1.0	9356	1401	1.21	F 127R77	4
13	528	109.04	1.46	FAF67	4	1.1	8214	1230	1.37	FF 127R77	4
14	465	95.94	1.66	F 67	4	1.3	7246	1085	1.56		
15	439	90.59	1.76	FF 67	4						
18	378	77.97	2.0								
21	320	66.13	2.4			1.1	8301	1243	0.89		
23	289	59.70	2.7			1.3	7259	1087	1.02	FA 107R77	4
						1.5	6344	950	1.16	FAF107R77	4
11	616	127.27	0.91	FA 57	4	1.7	5570	834	1.32	F 107R77	4
13	533	110.01	1.06	FAF57	4	1.9	4915	736	1.50	FF 107R77	4
15	453	93.47	1.25	F 57	4	2.2	4274	640	1.72		
17	404	83.46	1.40	FF 57	4						

输出转速	输出扭矩	传动比	使用系数	机型号	极数	输出转速	输出扭矩	传动比	使用系数	机型号	极数
Output speed	Output torque	Ratio	Service factor	Type	Pole	Output speed	Output torque	Ratio	Service factor	Type	Pole
r/min	Nm	i	f _s	Type	p	r/min	Nm	i	f _s	Type	p
1.1kW						1.1kW					
2.0	4675	700	0.86			17	589	83.46	0.96		
2.3	4080	611	0.99	FA 97R57	4	19	516	73.16	1.09		
2.6	3566	534	1.13	FAF97R57	4	20	482	68.38	1.17	FA 57	4
3.0	3152	472	1.28	F 97R57	4	24	417	59.10	1.35	FAF57	4
3.4	2738	410	1.48	FF 97R57	4	28	354	50.22	1.59	F 57	4
3.8	2451	367	1.65			31	316	44.84	1.78	FF 57	4
						37	270	38.30	2.1		
3.1	3019	452	0.93	FA 87R57	4	39	253	35.87	2.2		
4.1	2304	345	1.22	FAF87R57	4	46	213	30.22	2.6		
4.7	2003	300	1.41	F 87R57	4						
5.6	1663	249	1.70	FF 87R57	4						
						25	396	56.09	0.95		
2.7	3707	255.25	1.95	FA 107	8	29	336	47.66	1.12		
3.2	3123	215.04	2.3	FAF107	8	33	300	42.55	1.25		
3.4	2894	199.31	2.5	F 107	8	39	256	36.34	1.47	FA 47	4
3.8	2594	178.64	2.8	FF 107	8	41	240	34.04	1.57	FAF47	4
						46	216	30.64	1.74	F 47	4
3.3	3002	276.64	1.35	FA 97	6	48	205	29.11	1.83	FF 47	4
3.6	2765	254.79	1.46	FAF97	6	49	202	28.67	1.86		
4.0	2456	226.34	1.65	F 97	6	55	180	25.54	2.1		
4.8	2045	188.50	2.0	FF 97	6	65	153	21.66	2.5		
5.2	1908	175.83	2.1			72	138	19.56	2.7		
						44	224	31.69	0.84		
5.1	1951	276.64	2.1	FA 97	4	50	198	28.09	0.95		
5.5	1797	254.79	2.2	FAF97	4	59	168	23.88	1.12		
6.2	1596	226.34	2.5	F 97	4	68	145	20.57	1.30		
						73	136	19.27	1.38		
						82	120	17.03	1.57		
3.3	2951	271.92	0.96			98	101	14.33	1.86		
3.6	2766	254.93	1.02	FA 87	6	109	91	12.87	2.1	FA 37	4
4.0	2480	228.57	1.14	FAF87	6	126	78	11.08	2.3	FAF37	4
4.6	2136	196.85	1.32	F 87	6	134	73	10.42	2.4	F 37	4
5.1	1942	178.95	1.45	FF 87	6	156	63	8.97	2.6	FF 37	4
5.7	1732	159.61	1.63			175	56	8.01	2.7		
						206	48	6.81	2.8		
5.2	1911	271.92	1.48			229	43	6.11	2.9		
5.5	1798	254.93	1.57			266	37	5.27	3.2		
6.1	1612	228.57	1.75	FA 87	4	283	35	4.95	3.2		
7.1	1388	196.85	2.0	FAF87	4	329	30	4.26	3.4		
7.8	1262	178.95	2.2	F 87	4	367	27	3.81	3.7		
8.8	1126	159.61	2.5	FF 87	4						
10	946	134.16	3.0								
11	870	123.29	3.2								
						1.5kW					
7.1	1399	198.31	1.01			0.58	22102	2427	0.77		
7.4	1329	188.40	1.06			0.64	19898	2185	0.85		
8.4	1174	166.47	1.20			0.72	17703	1944	0.96		
9.8	1003	142.27	1.41	FA 77	4	0.84	15244	1674	1.11	FA 157R97	4
11	920	130.42	1.53	FAF77	4	1.1	11911	1308	1.42	FAF157R97	4
12	807	114.45	1.75	F 77	4	1.2	10646	1169	1.59	F 157R97	4
13	765	108.46	1.84	FF 77	4	1.5	8679	953	1.95	FF 157R97	4
15	670	94.93	2.1			1.7	7695	845	2.2		
16	603	85.52	2.3			3.1	4062	446	4.2		
19	529	75.02	2.7			4.7	2741	301	6.2		
						0.86	14744	1619	0.77		
12	853	120.79	0.9			1.0	12758	1401	0.88	FA 127R77	4
13	769	109.04	1.0			1.1	11201	1230	1.01	FAF127R77	4
15	677	95.94	1.1			1.3	9881	1085	1.14	F 127R77	4
15	639	90.59	1.2			1.5	8533	937	1.32	FF 127R77	4
18	550	77.97	1.4	FA 67	4	1.7	7531	827	1.50		
21	466	66.13	1.7	FAF67	4	1.9	6675	733	1.69		
23	421	59.70	1.8	F 67	4	2.2	5828	640	1.94		
27	371	52.53	2.1	FF 67	4						
28	350	49.60	2.2								
33	298	42.23	2.6			1.5	8651	950	0.83	FA 107R77	4
36	271	38.38	2.7			1.7	7595	834	0.95	FAF107R77	4
42	234	33.24	3.0			1.9	6702	736	1.08	F 107R77	4
						2.2	5710	627	1.26	FF 107R77	4

输出转速	输出扭矩	传动比	使用系数	机型号	极数	输出转速	输出扭矩	传动比	使用系数	机型号	极数
Output speed	Output torque	Ratio	Service factor	Type	Pole	Output speed	Output torque	Ratio	Service factor	Type	Pole
r/min	Nm	i	f _s	Type	p	r/min	Nm	i	f _s	Type	p
4kW						5.5kW					
8.2	4385	175.83	0.92			2.5	18699	576	0.90		
9.2	3919	157.16	1.03			2.9	16329	503	1.04		
10	3528	141.47	1.15			3.2	14479	446	1.17	FA 157R97	4
11	3195	128.12	1.27			4.1	11460	353	1.48	FAF157R97	4
13	2833	113.61	1.43	FA 97	4	4.8	9771	301	1.73	F 157R97	4
14	2561	102.72	1.58	FAF97	4	5.3	8830	272	1.92	FF 157R97	4
15	2427	97.31	1.67	F 97	4	6.2	7499	231	2.3		
16	2263	90.77	1.79	FF 97	4	7.1	6558	202	2.6		
18	2023	81.13	2.0			7.3	6363	196	2.7		
20	1821	73.03	2.2								
22	1649	66.14	2.5			3.5	13537	417	0.83		
						3.9	12109	373	0.93	FA 127R87	4
13	2730	109.49	1.03			4.6	10129	312	1.11	FAF127R87	4
15	2441	97.89	1.16			4.9	9512	293	1.19	F 127R87	4
16	2195	88.01	1.28	FA 87	4	5.5	8505	262	1.33	FF 127R87	4
19	1905	76.39	1.48	FAF87	4	6.4	7337	226	1.54		
21	1706	68.40	1.65	F 87	4						
25	1415	56.75	1.99	FF 87	4						
29	1254	50.29	2.2			3.4	13732	423	0.82	FA 127R77	4
32	1128	45.22	2.5			3.9	12044	371	0.94	FAF127R77	4
										F 127R77	4
										FF 127R77	4
22	1653	66.28	0.85			2.7	18293	266.76	0.92		
25	1450	58.16	0.97			3.3	14977	218.40	1.1		
26	1374	55.12	1.03			4.0	12149	177.17	1.4		
30	1203	48.24	1.17			4.4	11269	164.33	1.5	FA 157	8
33	1084	43.46	1.30			5.1	9724	141.80	1.7	FAF157	8
38	951	38.12	1.48	FA 77	4	5.8	8581	125.14	2.0	F 157	8
43	839	33.64	1.68	FAF77	4	6.6	7440	108.49	2.3	FF 157	8
48	744	29.82	1.90	F 77	4	7.5	6619	96.53	2.6		
50	717	28.59	1.97	FF 77	4	8.3	5959	86.90	2.8		
56	636	25.50	2.2			9.1	5450	79.47	3.1		
57	635	25.47	2.2			10	4742	69.15	3.6		
67	534	21.43	2.6			4.2	11817	172.33	0.95	FA 127	8
73	491	19.70	2.9			4.7	10616	154.81	1.06	FAF127	8
						5.7	8620	125.71	1.31	F 127	8
						6.2	7555	116.00	1.42	FF 127	8
53	683	27.41	1.13			6.7	7373	215.04	0.98		
57	627	25.13	1.23			7.2	6834	199.31	1.06	FA 107	4
65	550	22.05	1.40			8.1	6125	178.64	1.18	FAF107	4
69	521	20.90	1.48			8.9	5530	161.28	1.31	F 107	4
79	456	18.29	1.69			9.8	5023	146.49	1.44	FF 107	4
87	411	16.48	1.88			11	4456	129.97	1.62		
100	361	14.46	2.1	FA 67	4	12	4044	117.94	1.79	FA 107	4
113	318	12.76	2.4	FAF67	4	14	3476	101.38	2.1	FAF107	4
127	282	11.31	2.7	F 67	4	16	3171	92.47	2.3	F 107	4
149	241	9.66	3.2	FF 67	4	16	3034	88.49	2.4	FF 107	4
150	240	9.61	2.1			17	2880	83.99	2.5		
158	227	9.11	2.4								
181	199	7.97	2.9			11	4393	128.12	0.92		
201	179	7.18	3.3			13	3895	113.61	1.04		
229	157	6.30	3.6			14	3522	102.72	1.15		
259	139	5.56	4.0			15	3336	97.31	1.21		
292	123	4.93	4.3			16	3112	90.77	1.30	FA 97	4
342	105	4.21	4.5			17	2985	87.06	1.35	FAF97	4
						18	2782	81.13	1.45	F 97	4
68	528	21.17	1.07			19	2620	76.40	1.54	FF 97	4
75	477	19.11	1.18			21	2504	73.03	1.68		
86	419	16.81	1.35			22	2268	66.14	1.78		
91	396	15.88	1.42			25	2011	58.65	2.0		
107	337	13.52	1.67			27	1818	53.03	2.2		
117	306	12.29	1.84	FA 57	4						
135	265	10.64	2.1	FAF57	4	16	3018	88.01	0.93	FA 87	4
155	232	9.31	1.70	F 57	4	19	2619	76.39	1.08	FAF87	4
176	204	8.19	1.93	FF 57	4	21	2345	68.40	1.20	F 87	4
186	193	7.73	2.0			25	1946	56.75	1.45	FF 87	4
219	164	6.58	2.4								
241	149	5.98	2.6								
278	129	5.18	3.0								

F

输出转速	输出扭矩	传动比	使用系数	机型号	极数	输出转速	输出扭矩	传动比	使用系数	机型号	极数
Output speed	Output torque	Ratio	Service factor	Type	Pole	Output speed	Output torque	Ratio	Service factor	Type	Pole
r/min	Nm	i	f _s	Type	p	r/min	Nm	i	f _s	Type	p
5.5kW						7.5kW					
29	1724	50.29	1.64			8.4	8023	85.80	2.1		
32	1550	45.22	1.82			9.2	7337	78.46	2.3	FA 157	8
37	1346	39.25	2.1			10.5	6385	68.28	2.7	FAF157	8
41	1205	35.14	2.3	FA 87	4	12	5634	60.25	3.0	F 157	8
49	1000	29.16	2.8	FAF87	4	13.8	4885	52.24	3.5	FF 157	8
42	1170	34.11	2.1	F 87	4	15.5	4346	46.48	3.9		
51	974	28.41	2.4	FF 87	4	18	3746	40.06	4.5		
54	909	26.50	3.1								
61	812	23.68	3.5								
30	1654	48.24	0.85			3.6	18709	266.76	0.90		
33	1490	43.46	0.95			4.4	15317	218.40	1.11		
38	1307	38.12	1.08			5.4	12425	177.17	1.36		
43	1153	33.64	1.22			5.8	11525	164.33	1.47		
48	1022	29.82	1.38			6.8	9945	141.80	1.70	FA 157	6
56	874	25.50	1.61	FA 77	4	7.7	8776	125.14	1.93	FAF157	6
57	873	25.47	1.61	FAF77	4	8.8	7609	108.49	2.2	F 157	6
67	735	21.43	1.92	F 77	4	9.9	6770	96.53	2.5	FF 157	6
73	675	19.70	2.1	FF 77	4	11	6095	86.90	2.8		
82	600	17.49	2.4			12	5573	79.47	3.0		
92	536	15.64	2.6			14	4850	69.15	3.5		
102	482	14.06	2.9			16	4280	61.02	4.0		
118	418	12.20	3.4			18	3711	52.91	4.6		
65	756	22.05	1.02			5.7	11816	126.36	0.95	FA 127	8
69	717	20.9	1.08			6.2	10776	115.24	1.05	FAF127	8
79	627	18.29	1.23			7.2	9326	99.73	1.21	F 127	8
87	565	16.48	1.36			8.2	8229	88.00	1.37	FF 127	8
100	496	14.46	1.50			5.6	12086	172.33	0.93	FA 127	6
113	438	12.76	1.55	FA 67	4	6.2	10857	154.81	1.04	FAF127	6
127	388	11.31	1.70	FAF67	4	7.6	8816	125.71	1.28	F 127	6
149	331	9.66	1.76	F 67	4	8.3	8135	116.00	1.39	FF 127	6
150	329	9.61	2.0	FF 67	4						
158	312	9.11	2.1			8.5	7947	172.33	1.42	FA 127	4
181	273	7.97	2.3			9.4	7139	154.81	1.58	FAF127	4
201	246	7.18	2.4			12	5797	125.71	1.95	F 127	4
229	216	6.30	2.7								
259	191	5.56	2.9			8.2	8238	178.64	0.88		
292	169	4.93	3.1			9.1	7437	161.28	0.97		
342	144	4.21	3.3			10	6755	146.49	1.07		
						11	5994	129.97	1.20	FA 107	4
86	576	16.81	0.98			12	5439	117.94	1.33	FAF107	4
91	544	15.88	1.04			14	4675	101.38	1.54	F 107	4
107	464	13.52	1.22			16	4264	92.47	1.69	FF 107	4
117	421	12.29	1.34	FA 57	4	16	4081	88.49	1.77		
135	365	10.64	1.55	FAF57	4	17	3873	83.99	1.86		
176	281	8.19	1.41	F 57	4	20	3436	74.52	2.1		
186	265	7.73	1.49	FF 57	4	22	3118	67.62	2.3		
219	226	6.58	1.75								
241	205	5.98	1.93			15	4487	97.31	0.90		
278	178	5.18	2.2			16	4186	90.77	0.97		
						17	4015	87.06	1.01		
						18	3741	81.13	1.08		
						19	3523	76.40	1.15		
						21	3229	70.03	1.25	FA 97	4
						22	3050	66.14	1.33	FAF97	4
						25	2705	58.65	1.49	F 97	4
						28	2445	53.03	1.65	FF 97	4
						32	2072	44.94	1.95		
						33	2023	43.87	2.0		
						37	1810	39.26	2.2		
						40	1704	36.96	2.4		
						43	1580	34.26	2.6		
						44	1514	32.83	2.7		
						48	1416	30.70	2.9		
7.5kW											
4.6	13812	312	0.82	FA 127R87	4						
4.9	12971	293	0.87	FAF127R87	4						
5.5	11598	262	0.97	F 127R87	4						
6.4	10005	226	1.13	FF 127R87	4						
7.2	8854	200	1.27								
3.3	20350	217.62	0.83								
4.0	16664	178.20	1.02	FA 157	8						
4.4	15238	162.96	1.11	FAF157	8						
5.1	13260	141.80	1.28	F 157	8						
5.8	11702	125.14	1.45	FF 157	8						
6.6	10145	108.49	1.67								
7.5	9027	96.53	1.87								

F

输出转速	输出扭矩	传动比	使用系数	机型号	极数	输出转速	输出扭矩	传动比	使用系数	机型号	极数
Output speed	Output torque	Ratio	Service factor	Type	Pole	Output speed	Output torque	Ratio	Service factor	Type	Pole
r/min	Nm	i	f _s	Type	p	r/min	Nm	i	f _s	Type	p
7.5kW						11kW					
26	2617	56.75	1.08			15	6529	96.53	2.6	FA 157	4
29	2319	50.29	1.19			17	5877	86.90	2.9	FAF157	4
32	2085	45.22	1.27			18	5375	79.47	3.1	F 157	4
37	1810	39.25	1.41			21	4677	69.15	3.6	FF 157	4
42	1620	35.14	1.51			7.7	12864	125.71	0.88	FA 127	6
50	1345	29.16	1.75	FA 87	4	8.4	11732	116.00	0.96	FAF127	6
51	1327	28.41	1.74	FAF87	4	10	10153	99.73	1.11	F 127	6
55	1222	26.50	2.3	F 87	4	11	8958	88.00	1.26	FF 127	6
62	1092	23.68	2.6	FF 87	4	13	7737	76.00	1.46		
68	983	21.32	2.9			8.5	11656	172.33	0.97		
76	890	19.31	3.2			9.4	10471	154.81	1.08		
85	789	17.12	3.6			12	8502	125.71	1.33	FA 127	4
94	714	15.48	4.0			13	7846	116.00	1.44	FAF127	4
43	1551	33.64	0.91			15	6745	99.73	1.67	F 127	4
49	1375	29.82	1.03			17	5952	88.00	1.90	FF 127	4
57	1176	25.50	1.16			19	5140	76.00	2.2		
57	1175	25.47	1.20			12	7977	117.94	0.91		
68	988	21.43	1.43			14	6857	101.38	1.05		
74	908	19.70	1.55			16	6254	92.47	1.15		
83	807	17.49	1.75			17	5681	83.99	1.27		
93	721	15.64	1.95	FA 77	4	20	5040	74.52	1.43	FA 107	4
104	648	14.06	2.2	FAF77	4	22	4573	67.62	1.58	FAF107	4
120	563	12.20	2.5	F 77	4	25	3931	58.12	1.84	F 107	4
134	504	10.93	2.8	FF 77	4	29	3431	50.73	2.1	FF 107	4
156	431	9.35	2.4			34	2910	43.03	2.5		
176	383	8.30	2.7			43	2285	33.78	3.2		
197	342	7.42	3.0			53	1855	27.43	3.9		
219	308	6.67	3.3			58	1712	25.31	4.2		
252	267	5.79	3.8			22	4473	66.14	0.90		
281	239	5.19	4.2			25	3967	58.65	1.02		
340	198	4.30	4.8			28	3587	53.03	1.13		
11kW						11kW					
4.9	19275	301	0.88	FA 157R97	4	32	3040	44.94	1.33	FA 97	4
5.4	17418	272	0.97	FAF157R97	4	37	2655	39.26	1.52	FAF97	4
6.3	14793	231	1.14	F 157R97	4	43	2317	34.26	1.74	F 97	4
7.2	12936	202	1.31	FF 157R97	4	44	2220	32.83	1.82	FF 97	4
7.4	12551	196	1.35			48	2076	30.70	1.95		
6.5	14472	226	0.78	FA 127R87	4	53	1875	27.72	2.2		
7.3	12807	200	0.88	FAF127R87	4	58	1703	25.18	2.4		
8.7	10758	168	1.05	F 127R87	4	65	1511	22.34	2.7		
				FF 127R87	4	37	2655	39.25	0.96		
5.1	19181	141.80	0.88	FA 157	8	42	2377	35.14	1.03		
5.8	16928	125.14	1.00	FAF157	8	50	1972	29.16	1.20		
6.7	14675	108.49	1.15	F 157	8	55	1792	26.50	1.57	FA 87	4
7.6	13058	96.53	1.30	FF 157	8	62	1602	23.68	1.76	FAF87	4
5.5	18036	177.17	0.94			68	1442	21.32	1.96	F 87	4
5.9	16729	164.33	1.01			76	1306	19.31	2.16	FF 87	4
6.8	14435	141.80	1.17	FA 157	6	85	1158	17.12	2.4		
7.8	12739	125.14	1.33	FAF157	6	94	1047	15.48	2.7		
8.9	11044	108.49	1.53	F 157	6	111	887	13.12	3.2		
10	9827	96.53	1.72	FF 157	6	74	1332	19.70	1.06		
11	8847	86.90	1.91			83	1183	17.49	1.19		
12	8090	79.47	2.1			93	1058	15.64	1.33		
5.5	18042	266.76	0.94			104	951	14.06	1.48		
6.7	14776	218.46	1.15			120	825	12.20	1.61		
8.2	12053	177.17	1.40	FA 157	4	134	739	10.93	1.71	FA 77	4
8.9	11114	164.33	1.52	FAF157	4	156	632	9.35	1.81	FAF77	4
10	9591	141.80	1.76	F 157	4	176	561	8.30	1.91	F 77	4
12	8464	125.14	2.0	FF 157	4	197	502	7.42	2.0	FF 77	4
13	7338	108.49	2.3			219	451	6.67	2.3		
						252	392	5.79	2.6		
						281	351	5.19	2.9		
						340	291	4.30	3.3		

输出转速	输出扭矩	传动比	使用系数	机型号	极数	输出转速	输出扭矩	传动比	使用系数	机型号	极数
Output speed	Output torque	Ratio	Service factor	Type	Pole	Output speed	Output torque	Ratio	Service factor	Type	Pole
r/min	Nm	i	f _s	Type	p	r/min	Nm	i	f _s	Type	p
18.5kW						22kW					
69	2409	21.32	1.17			112	1763	13.12	1.27		
76	2182	19.31	1.29			128	1540	11.46	1.43		
86	1934	17.12	1.46			153	1287	9.58	1.58	FA 87	4
95	1749	15.48	1.50			174	1137	8.46	1.60	FAF87	4
112	1482	13.12	1.61			196	1008	7.50	1.70	F 87	4
128	1295	11.46	1.70	FA 87	4	217	911	6.78	1.83	FF 87	4
153	1082	9.58	1.80	FAF87	4	256	773	5.75	1.86		
174	956	8.46	1.88	F 87	4	293	674	5.02	2.1		
196	847	7.50	1.90	FF 87	4	350	564	4.20	2.4		
217	766	6.78	2.0			30kW					
256	650	5.75	2.2			14	19876	108.49	0.85		
296	567	5.02	2.5			15	17685	96.53	0.96		
350	474	4.20	2.9			17	15920	86.90	1.06	FA 157	4
22kW						18	14559	79.47	1.16	FAF157	4
10	19654	96.53	0.86	FA 157	6	21	12669	69.15	1.34	F 157	4
11	17693	86.90	0.96	FAF157	6	24	11179	61.02	1.51	FF 157	4
12	16180	79.47	1.05	F 157	6	28	9693	52.91	1.75		
14	14079	69.15	1.20	FF 157	6	31	8623	47.07	2.0		
						36	7433	40.57	2.3		
10	19051	141.80	0.89			19	13924	76.00	0.81		
12	16813	125.14	1.01			21	12938	70.62	0.87		
14	14576	108.49	1.16			23	11800	64.41	0.96		
15	12969	96.53	1.30			26	10212	55.74	1.10		
17	11675	86.90	1.45	FA 157	4	30	9012	49.19	1.25	FA 127	4
18	10677	79.47	1.58	FAF157	4	35	7783	42.48	1.45	FAF127	4
21	9290	69.15	1.82	F 157	4	39	6883	37.57	1.58	F 127	4
24	8198	61.02	2.1	FF 157	4	47	5786	31.58	1.6	FF 127	4
28	7108	52.91	2.4			54	4961	26.92	1.95		
31	6324	47.07	2.7			58	4672	25.50	2.4		
36	5451	40.57	3.1			59	4536	24.97	2.8		
45	4430	32.97	3.8			68	3948	21.55	2.9		
						77	3483	19.01	3.2		
15	13399	99.73	0.84			34	7883	43.03	0.92		
17	11823	88.00	0.95			39	6890	37.61	1.05		
19	10211	76.00	1.10	FA 127	4	46	5826	31.80	1.24		
21	9488	70.62	1.19	FAF127	4	54	5025	27.43	1.44	FA 107	4
23	8653	64.41	1.30	F 127	4	58	4637	25.31	1.56	FAF107	4
26	7489	55.74	1.51	FF 127	4	68	3987	21.76	1.81	F 107	4
30	6609	49.19	1.71			77	3518	19.20	2.1	FF 107	4
35	5707	42.48	1.98			89	3038	16.58	2.4		
						100	2688	14.67	2.7		
25	7808	58.12	0.92			119	2259	12.33	2.9		
29	6816	50.73	1.06			148	1825	9.96	3.3		
34	5781	43.03	1.25			66	4093	22.34	0.99		
39	5053	37.61	1.43	FA 107	4	73	3714	20.27	1.09		
44	4540	33.78	1.59	FAF107	4	84	3191	17.42	1.27		
46	4272	31.08	1.69	F 107	4	97	2787	15.21	1.31		
54	3685	27.43	1.96	FF 107	4	114	2363	12.90	1.44	FA 97	4
58	3400	25.31	2.1			130	2067	11.28	1.45	FAF97	4
68	2923	21.76	2.5			159	1698	9.27	1.67	F 97	4
77	2580	19.20	2.8			175	1541	8.41	1.83	FF 97	4
						203	1325	7.23	1.85		
53	3724	27.72	1.09			233	1156	6.31	1.86		
58	3383	25.18	1.19			275	980	5.35	2.1		
66	3001	22.34	1.35	FA 97	4	314	857	4.68	2.2		
73	2723	20.27	1.48	FAF97	4						
84	2340	17.42	1.73	F 97	4						
97	2043	15.21	2.0	FF 97	4						
114	1733	12.90	2.3								
130	1515	11.28	2.7								
						69	2864	21.32	0.98	FA 87	4
69	2864	21.32	0.98	FA 87	4	76	2594	19.31	1.09	FAF87	4
76	2594	19.31	1.09	FAF87	4	86	2300	17.12	1.23	F 87	4
86	2300	17.12	1.23	F 87	4	95	2080	15.48	1.36	FF 87	4
95	2080	15.48	1.36	FF 87	4						

输出转速	输出扭矩	传动比	使用系数	机型号	极数	输出转速	输出扭矩	传动比	使用系数	机型号	极数
Output speed	Output torque	Ratio	Service factor	Type	Pole	Output speed	Output torque	Ratio	Service factor	Type	Pole
r/min	Nm	i	f _s	Type	p	r/min	Nm	i	f _s	Type	p
37kW						45kW					
17	19503	86.90	0.87			54	7525	27.57	0.98		
19	17835	79.47	0.95			59	6862	25.14	1.07		
21	15519	69.15	1.09			68	5939	21.76	1.24		
24	13694	61.02	1.24	FA 157	4	77	5241	19.2	1.41		
28	11874	52.91	1.42	FAF157	4	89	4525	16.58	1.63	FA 107	4
31	10564	47.07	1.60	F 157	4	101	4004	14.67	1.80	FAF107	4
36	9105	40.57	1.86	FF 157	4	120	3365	12.33	1.90	F 107	4
45	7399	32.97	2.3			149	2719	9.96	2.0	FF 107	4
53	6275	27.96	2.7			153	2634	9.65	2.1		
						177	2276	8.34	2.2		
						201	2012	7.37	2.3		
						239	1692	6.20	2.6		
15	22261	99.19	0.51			55kW					
27	12509	55.74	0.90			24	20357	61.02	0.83		
35	9534	42.48	1.18			28	17651	52.91	0.96		
39	8432	37.57	1.31			31	15703	47.07	1.08	FA 157	4
47	7087	31.58	1.34			36	13534	40.57	1.25	FAF157	4
58	5723	25.50	1.44	FA 127	4	45	10999	32.97	1.54	F 157	4
55	6077	26.92	1.59	FAF127	4	53	9328	27.96	1.66	FF 157	4
60	5557	24.97	1.97	F 127	4	58	8484	25.43	1.81		
69	4836	21.55	2.3	FF 127	4	67	7393	22.16	2.3		
78	4266	19.01	2.4			75	6595	19.77	2.4		
90	3699	16.48	2.8			88	5621	16.85	3.0		
101	3292	14.67	3.1								
117	2837	12.64	3.2			39	12534	37.57	0.90		
144	2305	10.27	3.3			47	10535	31.58	1.07		
169	1966	8.76	3.3			58	8507	25.5	1.33		
190	1748	7.79	3.9			69	7189	21.55	1.57		
						78	6342	19.01	1.63		
54	6156	27.43	1.20			90	5498	16.48	1.88	FA 127	4
58	5680	25.31	1.30	FA 107	4	101	4894	14.67	2.1	FAF127	4
68	4883	21.76	1.51	FAF107	4	117	4217	12.64	2.2	F 127	4
77	4309	19.20	1.7	F 107	4	144	3426	10.27	2.3	FF 127	4
89	3721	16.58	2.0	FF 107	4	169	2922	8.76	2.4		
101	3292	14.67	2.1			190	2599	7.79	2.6		
120	2767	12.33	2.2			220	2242	6.72	2.9		
149	2235	9.96	2.3			271	1821	5.46	3.1		
153	2166	9.65	2.4			320	1545	4.63	3.7		
177	1872	8.34	2.6								
201	1654	7.37	2.7								
239	1391	6.20	3.1								
45kW						75kW					
21	18874	69.15	0.90			31	21413	47.07	0.79		
24	16655	61.02	1.02	FA 157	4	36	18456	40.57	0.92		
28	14442	52.91	1.17	FAF157	4	45	14999	32.97	1.13		
31	12848	47.07	1.32	F 157	4	53	12719	27.96	1.22	FA 157	4
36	11074	40.57	1.53	FF 157	4	58	11569	25.43	1.33	FAF157	4
45	8999	32.97	1.88			67	10081	22.16	1.68	F 157	4
53	7632	27.96	2.2			75	8994	19.77	1.78	FF 157	4
						88	7665	16.85	2.2		
30	13426	49.19	0.84			106	6351	13.96	2.5		
35	11595	42.48	0.97			124	5423	11.92	2.8		
39	10255	37.57	1.08								
47	8620	31.58	1.10			58	11600	25.50	0.97		
55	7391	26.92	1.18			69	9803	21.55	1.2		
58	6960	25.50	1.31			78	8648	19.01	1.2		
60	6758	24.97	1.62	FA 127	4	90	7497	16.48	1.4		
69	5882	21.55	1.92	FAF127	4	101	6674	14.67	1.5	FA 127	4
78	5189	19.01	2.0	F 127	4	117	5750	12.64	1.6	FAF127	4
90	4498	16.48	2.3	FF 127	4	144	4672	10.27	1.6	F 127	4
101	4004	14.67	2.6			169	3985	8.76	1.7	FF 127	4
117	3450	12.64	2.7			190	3544	7.79	1.9		
144	2803	10.27	2.8			220	3057	6.72	2.2		
169	2391	8.76	2.9			271	2484	5.46	2.3		
190	2126	7.79	3.2			320	2106	4.63	2.7		
220	1834	6.72	3.6								
271	1490	5.46	3.8								

F

输出转速	输出扭矩	传动比	使用系数	机型号	极数	输出转速	输出扭矩	传动比	使用系数	机型号	极数
Output speed	Output torque	Ratio	Service factor	Type	Pole	Output speed	Output torque	Ratio	Service factor	Type	Pole
r/min	Nm	i	f _s	Type	p	r/min	Nm	i	f _s	Type	p
90kW											
45	17998	32.97	0.94								
53	15263	27.96	1.02								
58	13882	25.43	1.11	FA 157	4						
67	12097	22.16	1.40	FAF157	4						
75	10792	19.77	1.48	F 157	4						
88	9198	16.85	1.84	FF 157	4						
106	7621	13.96	2.1								
124	6507	11.92	2.3								
58	13920	25.50	0.81								
69	11764	21.55	0.96								
78	10378	19.01	1.00								
90	8953	16.48	1.15								
101	8008	14.67	1.29	FA 127	4						
117	6900	12.64	1.33	FAF127	4						
144	5606	10.27	1.36	F 127	4						
169	4782	8.76	1.59	FF 127	4						
190	4253	7.79	1.60								
220	3668	6.72	1.79								
271	2981	5.46	1.89								
320	2528	4.63	2.2								
110kW											
53	18530	27.96	0.91								
67	14686	22.16	1.15	FA 157	4						
75	13102	19.77	1.22	FAF157	4						
88	11167	16.85	1.52	F 157	4						
107	9252	13.96	1.73	FF 157	4						
125	7900	11.92	1.90								
132kW											
67	17623	22.16	0.96	FA 157	4						
75	15723	19.77	1.02	FAF157	4						
88	13400	16.85	1.26	F 157	4						
107	11102	13.96	1.44	FF 157	4						
125	9480	11.92	1.59								
160kW											
88	16243	16.85	1.04	FA 157	4						
107	13457	13.96	1.19	FAF157	4						
125	11491	11.92	1.31	F 157	4						
125	11491	11.92	1.31	FF 157	4						
200kW											
88	20304	16.85	0.83	FA 157	4						
107	16821	13.96	0.95	FAF157	4						
125	14363	11.92	1.05	F 157	4						
125	14363	11.92	1.05	FF 157	4						

F

Mamax Permissible torque	输出转速 Output speed	传动比 Ratio	机 型 号 Type	功率 Power	Mamax Permissible torque	输出转速 Output speed	传动比 Ratio	机 型 号 Type	功率 Power
Nm	r/min	i	Type	kW/4p	Nm	r/min	i	Type	kW/4p
200	5.3	262	FA 37R17 FAF37R17 F 37R17 FF 37R17	0.18	1500	2.3	600	FA 77R37 FAF77R37 F 77R37 FF 77R37	0.55
	6.1	229				3.0	469		
	7.0	200				3.4	412		
	8.2	170				3.9	357		
	9.1	153	4.4	314		0.75			
	10	133							
11	129								
400	2.5	563	FA 47R17 FAF47R17 F 47R17 FF 47R17	0.18	3000	0.33	4245	FA 87R57 FAF87R57 F 87R57 FF 87R57	0.37
	2.9	477				0.37	3721		
	3.1	445				0.43	3244		
	3.6	389				0.48	2881		
	4.0	346				0.54	2575		
	4.6	304				0.63	2199		
	4.7	293	0.72	1930		0.25			
	6.0	230	0.81	1709		0.37			
	6.4	216	0.93	1493		0.55			
	7.4	188	1.1	1300		0.75			
7.9	176	1.2	1148	1.1					
9.4	148	1.4	1010	1.5					
11	130	1.6	887						
600	1.6	856	FA 57R37 FAF57R37 F 57R37 FF 57R37	0.18	4300	1.8	780	FA 97R57 FAF97R57 F 97R57 FF 97R57	0.55
	1.9	749				2.1	674		
	2.1	658				2.3	609		
	2.5	549				2.7	515		
	2.9	483				3.1	452		
	3.3	426				4.0	345		
	3.6	382	0.21	6532		0.18			
	4.2	330	0.24	5696		0.25			
	4.7	298	0.28	5032		0.37			
	5.3	262	0.32	4375		0.55			
6.2	226	0.35	3946	0.75					
7.0	200	0.41	3404	1.1					
8.4	166	0.47	2949	1.5					
9.1	152	0.54	2590	2.2					
10	134	0.61	2267	3					
820	1.2	1126	FA 67R37 FAF67R37 F 67R37 FF 67R37	0.18	7840	0.70	1989	FA 107R77 FAF107R77 F 107R77 FF 107R77	0.18
	1.4	984				0.80	1739		
	1.6	864				0.90	1542		
	1.9	722				1.0	1340		
	2.2	633				1.2	1182		
	2.6	527				1.3	1032		
	2.8	500	1.5	907		0.75			
	3.1	454	1.8	796		1.1			
	3.5	392	2.0	700		1.5			
	4.2	333	2.3	611		2.2			
4.7	297	2.6	534	3					
5.3	261	3.0	472						
5.8	238	3.5	410						
7.0	200	3.9	367						
1500	0.7	2024	FA 77R37 FAF77R37 F 77R37 FF 77R37	0.18	7840	4.9	288	FA 107R77 FAF107R77 F 107R77 FF 107R77	0.25
	0.81	1728				5.7	247		
	0.91	1543				0.12	11347		
	1.03	1354				0.14	10039		
	1.2	1196	0.16	8548					
	1.3	1050	0.18	7675					
1.5	907	0.21	6615	0.25					
1.7	810	0.24	5820						
2.0	710	0.27	5223						

表上所配功率均有超载,按实际条件确定的转矩不得大于减速机额定转矩。 The power are all overload in the table. The decided torque according to operating condition should not more than gear units' nominal torque.

Mamax	输出转速	传动比	机 型 号	功率	Mamax	输出转速	传动比	机 型 号	功率
Permissible torque	Output speed	Ratio	Type	Power	Permissible torque	Output speed	Ratio	Type	Power
Nm	r/min	i	Type	kW/4p	Nm	r/min	i	Type	kW/4p
7840	0.30	4567	FA 107R77 FAF107R77 F 107R77 FF 107R77	0.37	18000	0.04	31434	FA 157R97 FAF157R97 F 157R97 FF 157R97	2.2
	0.40	3442				0.05	26173		
	0.46	3037		0.06		23464			
	0.50	2756		0.07		20212			
	0.59	2369		0.08		17984			
	0.67	2068		0.09		16358			
	0.76	1826		0.10		13751			
	0.88	1597		0.11		12235			
	1.0	1401		0.20		7065			
	1.1	1243		0.22		6286			
	1.3	1087		0.26		5404			
	1.5	950		0.14		10033			
	1.7	834		0.16		9021			
	1.9	736		0.17		8026			
	2.3	627		0.29		4831			
	12000	2.5		560		0.34	4124		
2.9		489	0.50	2776					
3.3		427	0.57	2427					
4.0		362	0.64	2185					
4.3		333	0.39	3602					
0.08		16787	0.44	3205					
0.09		14838	0.73	1944					
0.11		13014	0.85	1674					
0.12		11748	1.00	1420					
0.14		10271	1.1	1308					
0.16		8901	1.2	1169					
0.18		7703	1.5	953					
0.21		6768	1.7	845					
0.23		5975	1.9	764					
0.27		5076	2.1	680					
0.31		4466	2.5	576					
0.36	3868	2.9	503						
0.41	3403	3.3	446						
0.47	2987	4.9	301						
0.52	2693	5.4	272						
0.59	2376	6.3	231						
0.68	2054	7.2	202						
0.78	1798	4.9	196						
0.86	1619	0.59	2376						
1.0	1401	0.68	2054						
1.2	1230	0.78	1798						
1.3	1085	0.86	1619						
1.5	937	1.0	1401						
1.7	827	1.2	1230						
1.9	733	1.3	1085						
2.2	640	1.5	937						
2.7	542	1.7	827						
2.9	489	1.9	733						
3.4	423	2.2	640						
3.9	371	2.7	542						
3.0	483	2.9	489						
3.5	417	3.4	423						
3.9	373	3.9	371						
4.7	312	3.0	483						
5.0	293	3.5	417						
7.3	200	3.9	373						

F

表上所配功率均有超载,按实际条件确定的转矩不得大于减速机额定转矩。 The power are all overload in the table. The decided torque according to operating condition should not more than gear units' nominal torque.

F37

FA37/FAF37/FAZ37空心轴 /Hollow shaft

F..T37

FA37

FAZ37

FF37

FAF37

电机需方配或配特殊电机时需加联接法兰

F.37R17

F.S37

注：其余尺寸见相对应结构形式
Note:For other values please refer to the o-posed structure.

When equipping the user's motor or the special one,the flange is required to be connected.

Y2电机型号 Motor size	63	71		80		90S	90L	100	
功率/4P Power/(kW)	0.18	0.25	0.37	0.55	0.75	1.1	1.5	2.2	3
L3	235	245		278		304	328	340	
G	130	145		175		195	195	215	
L2	71	71		71		71	71	93	

注:1.以上壳体为通用件,安装尺寸均可相互参照 2."F.."表示F、FA、FF、FAF、FAZ
Note:1.The above housings are common parts.The mounting dimensions may consult each other. 2."F.."mean F、FA、FF、FAF、FAZ

F

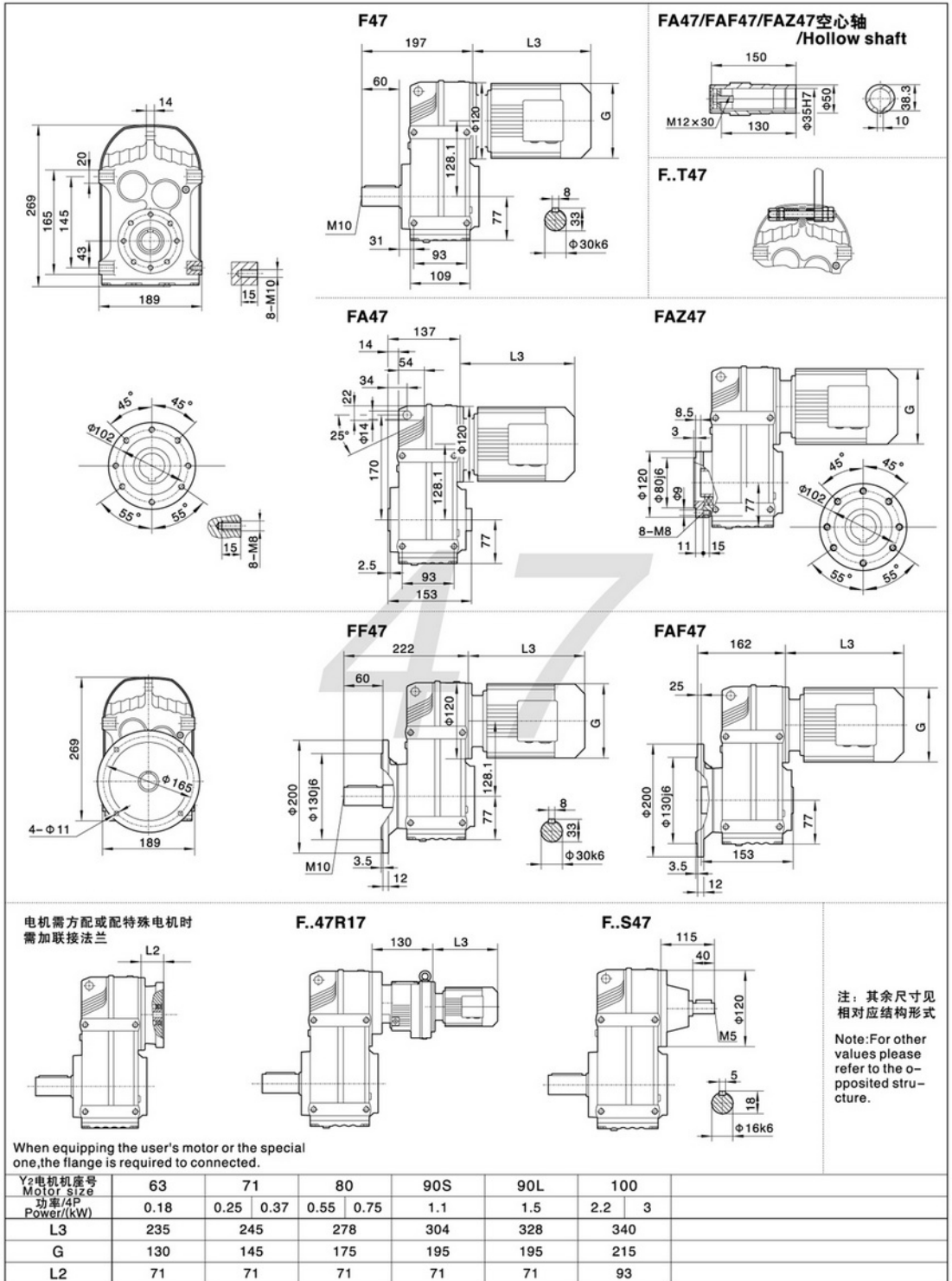

F

注:1.以上壳体为通用件.安装尺寸均可相互参照 2."F."表示F, FA, FF, FAF, FAZ
Note:1.The above housings are common parts.The mounting dimensions may consult each other. 2."F."mean F, FA, FF, FAF, FAZ

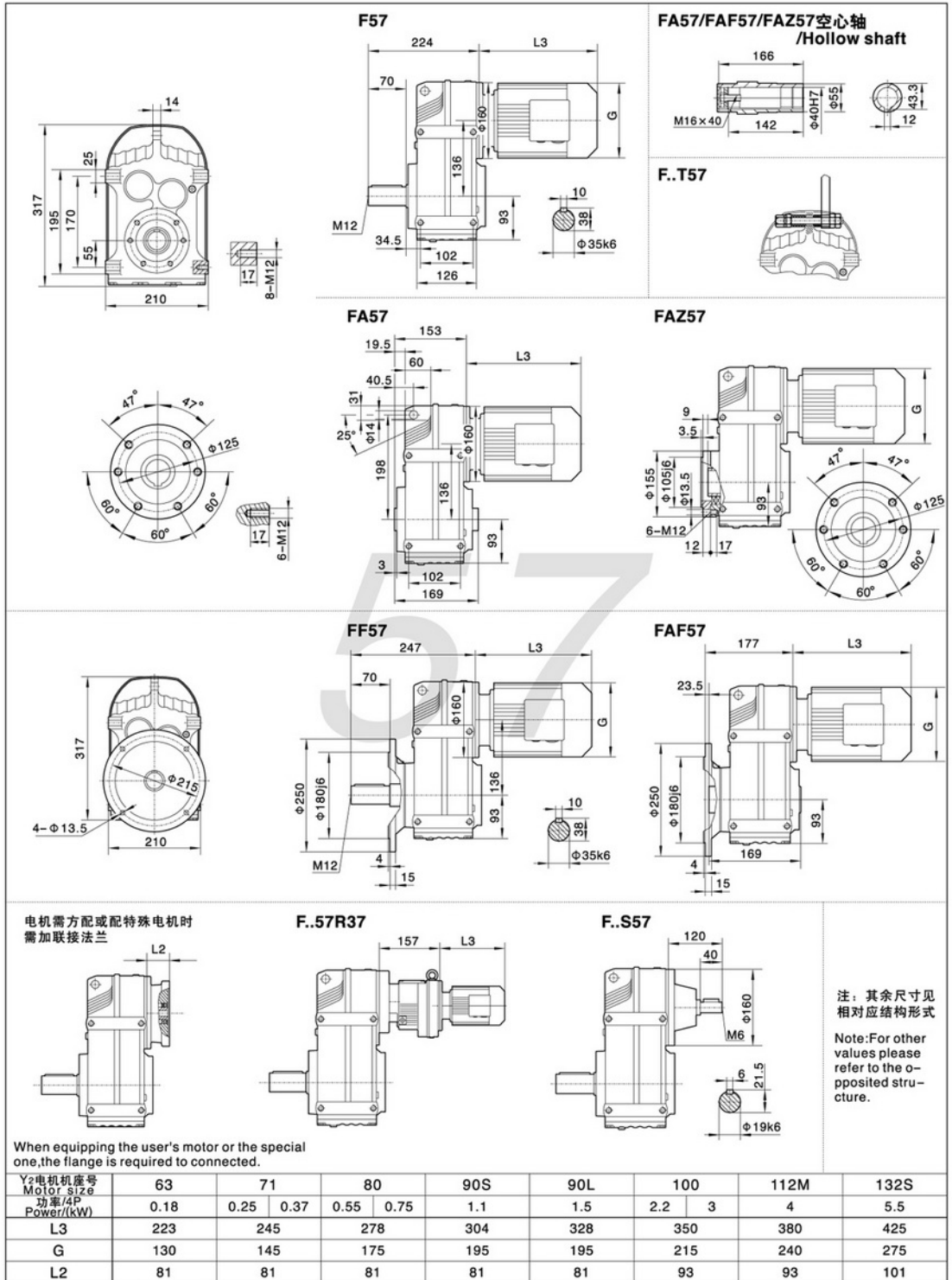

注:1.以上壳体为通用件,安装尺寸均可相互参照 2."F.."表示F、FA、FF、FAF、FAZ
Note:1.The above housings are common parts.The mounting dimensions may consult each other. 2."F.."mean F、FA、FF、FAF、FAZ

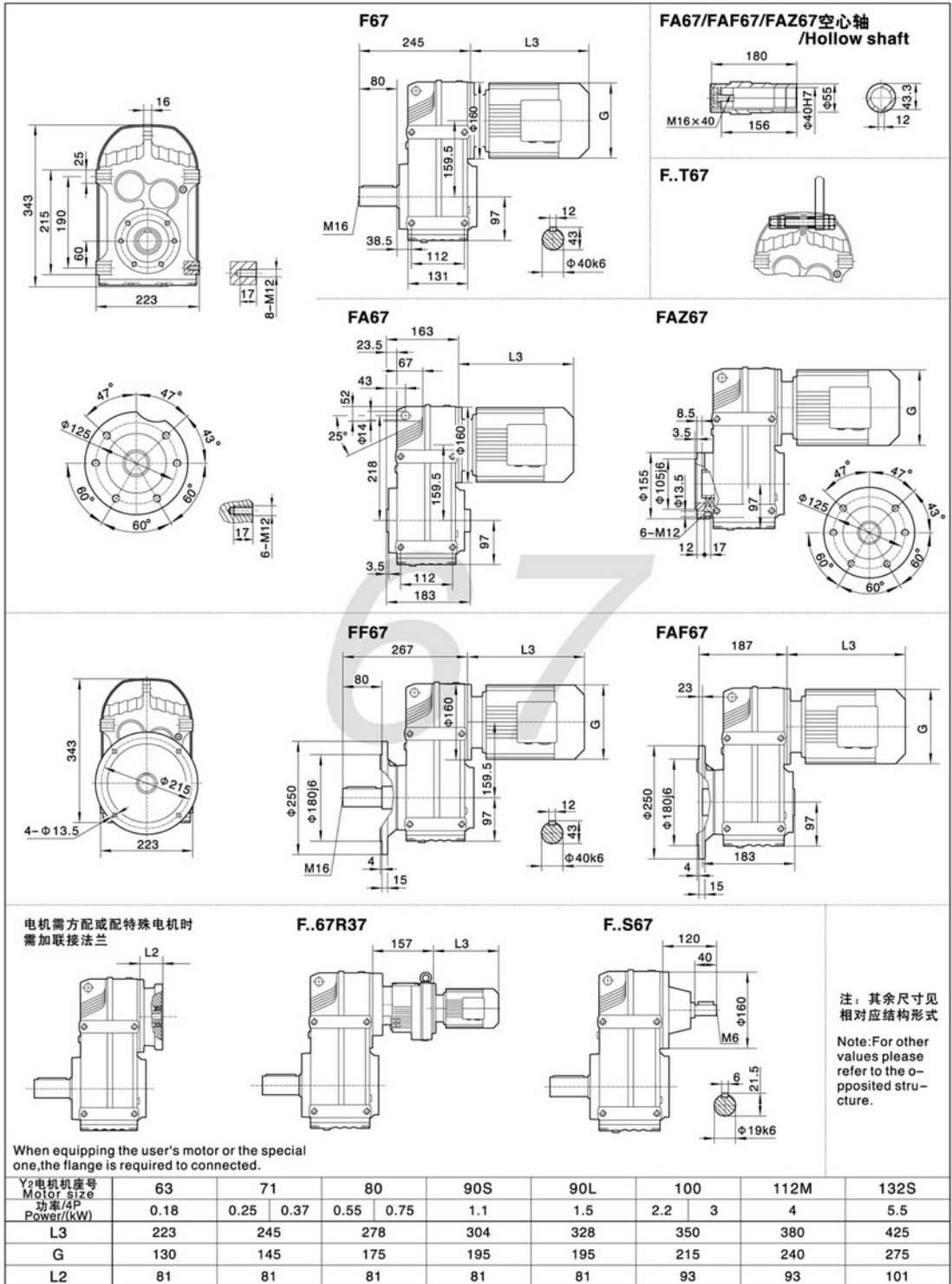

F

注:1.以上壳体为通用件.安装尺寸均可相互参照 2."F."表示F, FA, FF, FAF, FAZ
Note:1.The above housings are common parts.The mounting dimensions may consult each other. 2."F."mean F, FA, FF, FAF, FAZ

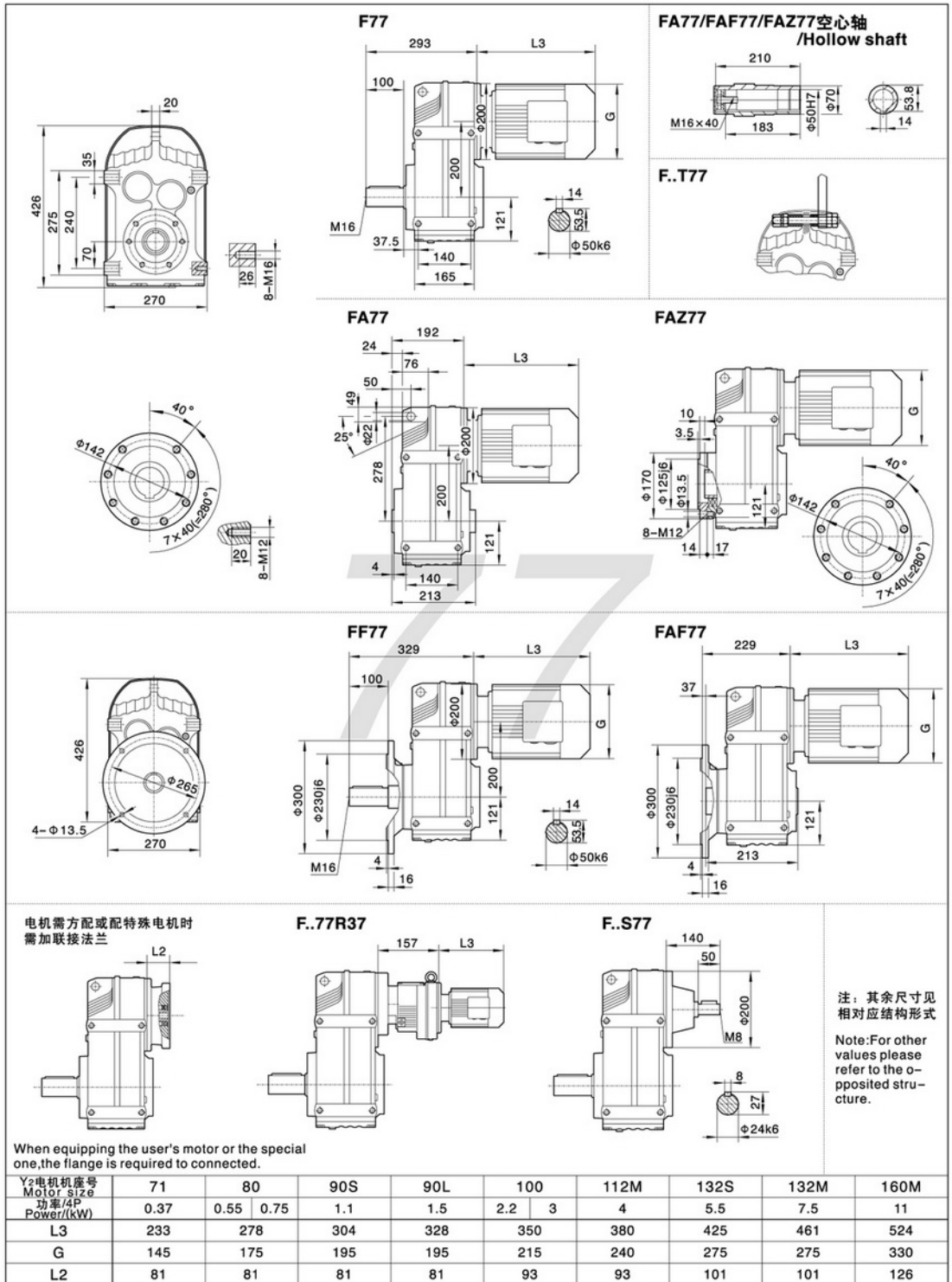

F

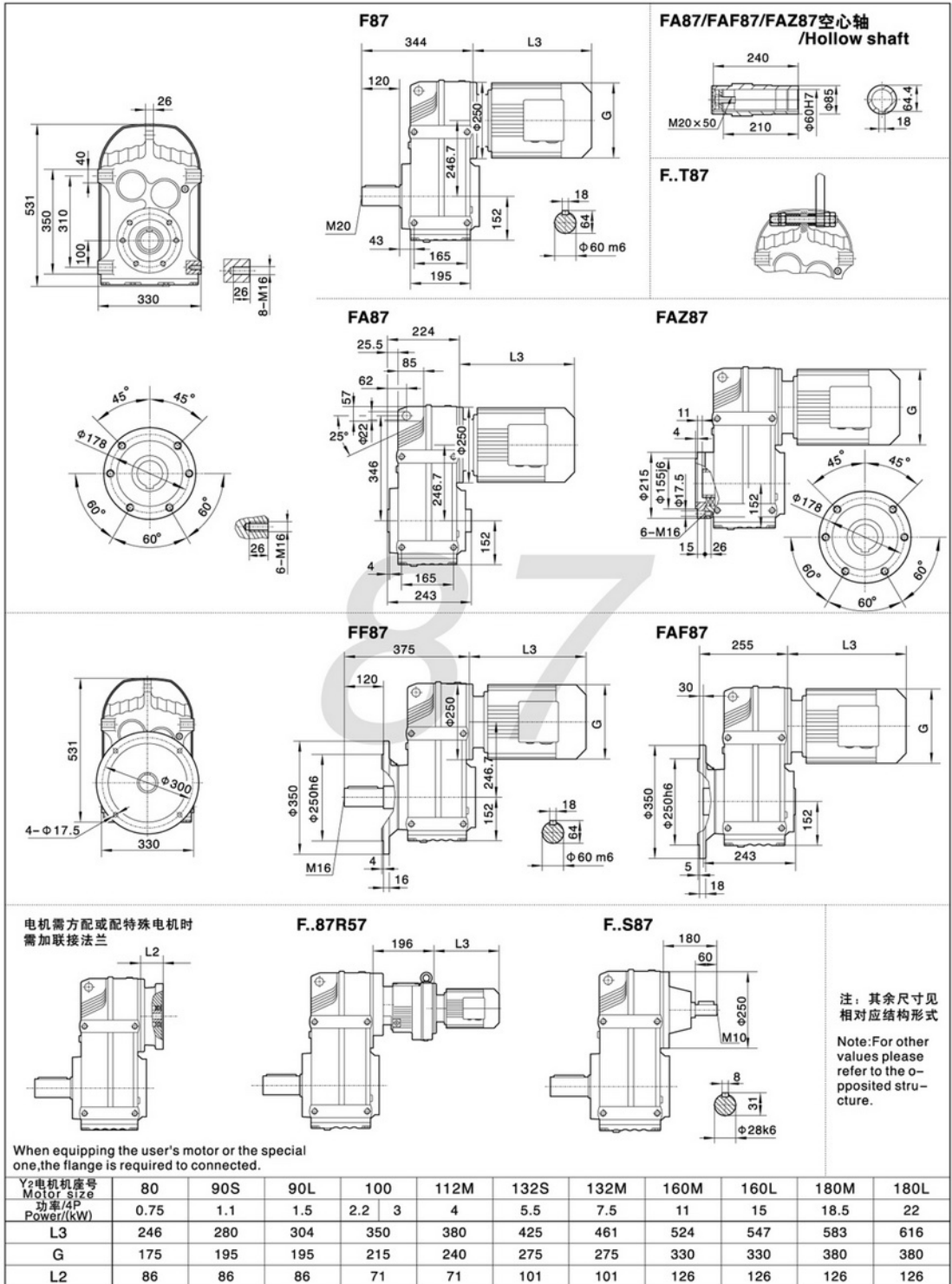

注:1.以上壳体为通用件.安装尺寸均可相互参照 2."F.."表示F、FA、FF、FAF、FAZ
Note:1.The above housings are common parts.The mounting dimensions may consult each other. 2."F.."mean F、FA、FF、FAF、FAZ

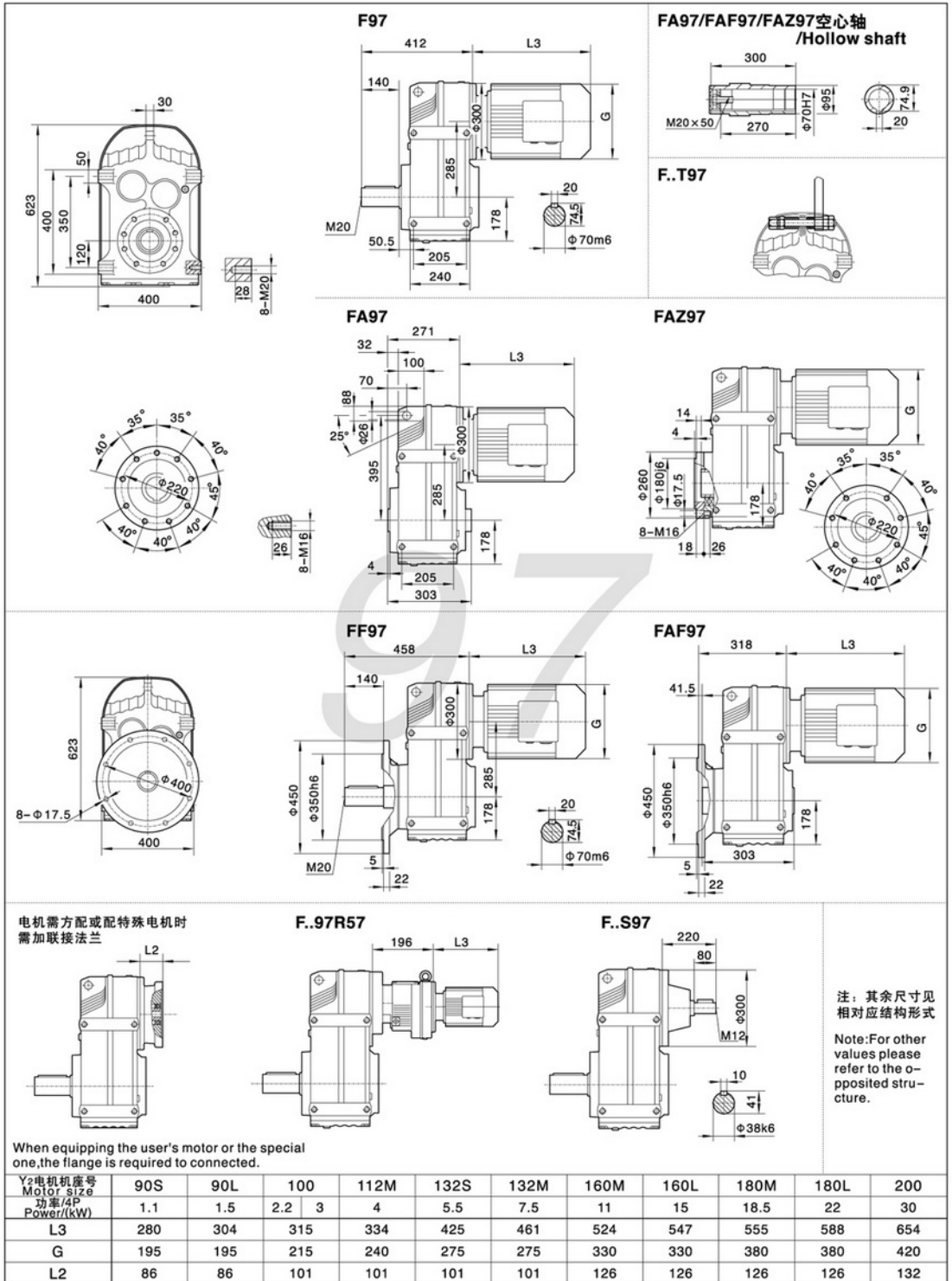

F

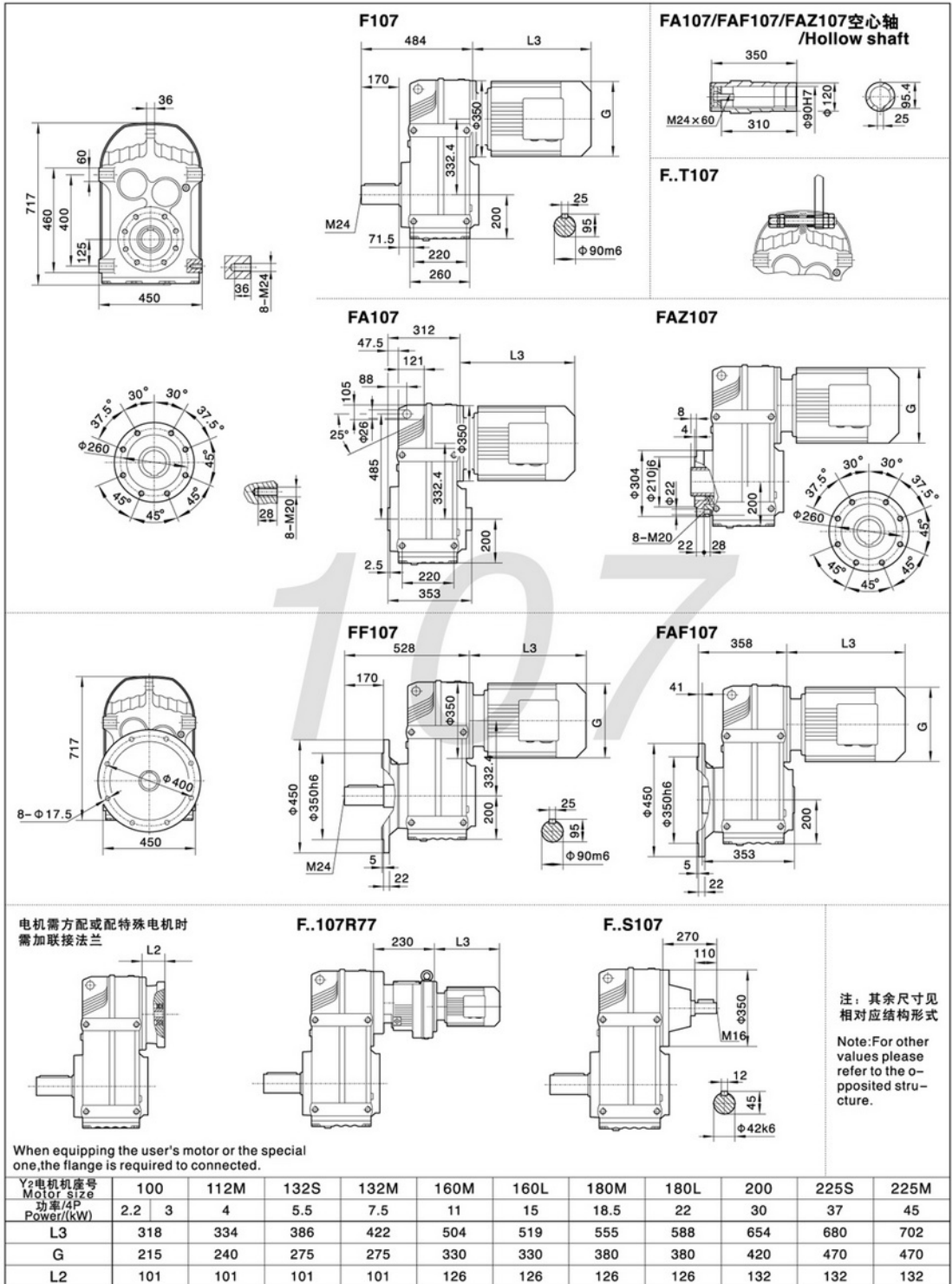

F

注:1. 以上壳体为通用件,安装尺寸均可相互参照 2."F."表示F, FA, FF, FAF, FAZ
Note:1. The above housings are common parts.The mounting dimensions may consult each other. 2."F."mean F, FA, FF, FAF, FAZ

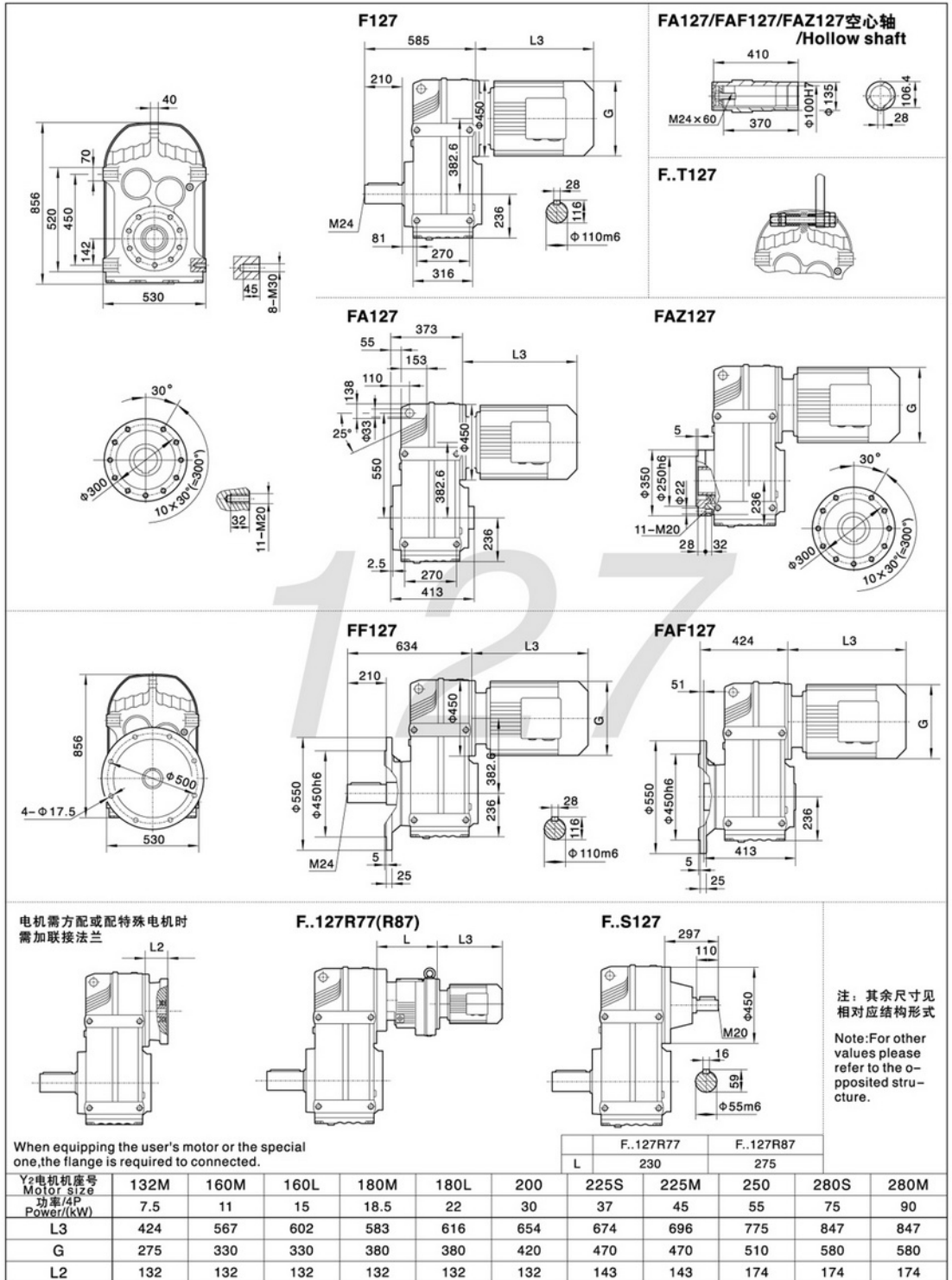

F

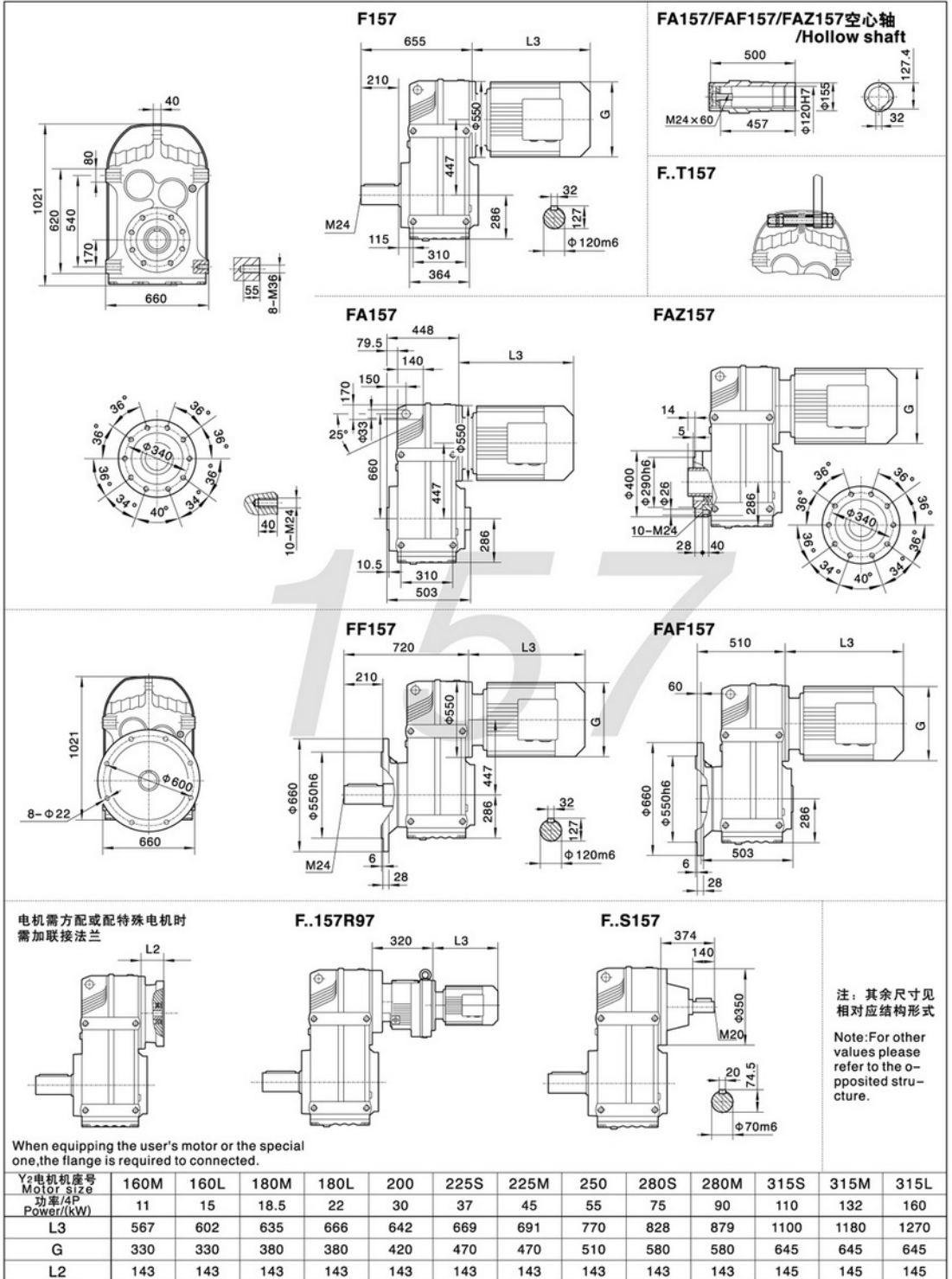

F

注:1.以上壳体为通用件,安装尺寸均可相互参照 2."F."表示F、FA、FF、FAF、FAZ
Note:1. The above housings are common parts. The mounting dimensions may consult each other. 2."F." mean F、FA、FF、FAF、FAZ